

Hendricks RockHunter CW Transceiver w/switched crystal board assembly instructions

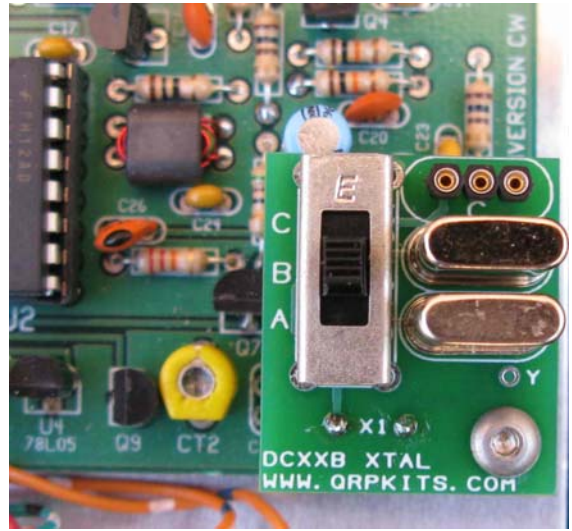

First off, check to see if the parts match the parts list...

- 1 – band specific additional crystal
- 1 – 3 pin SIP socket
- 1 – DP3T slide switch
- 1 – 4" - 20AWG tinned wire
- 1 – PCB
- 3 – 4-40 x 1/4" panhead screws
- 1 – 4-40 x 3/4" panhead screw
- 1 - #4 x 1/2" long nylon spacer
- 1 – BNC female chassis connector
- 1 – Push-in DC power connector
- 2 - 1/8" stereo chassis jacks
- 1 – push button switch
- 4 - rubber feet
- 1 – decal set
- 1 – aluminum chassis
- 1 lot – Teflon hook-up wire

Please read all the instructions before starting. You should only start using this set of instructions after you have completed and tested the main DCxxB board. These instructions cover the multi-crystal board and mounting to the RockHound open chassis.

Most of the assembly is done inside the chassis. So now, you need to prepare the chassis with the decals, using the picture below as a guide.

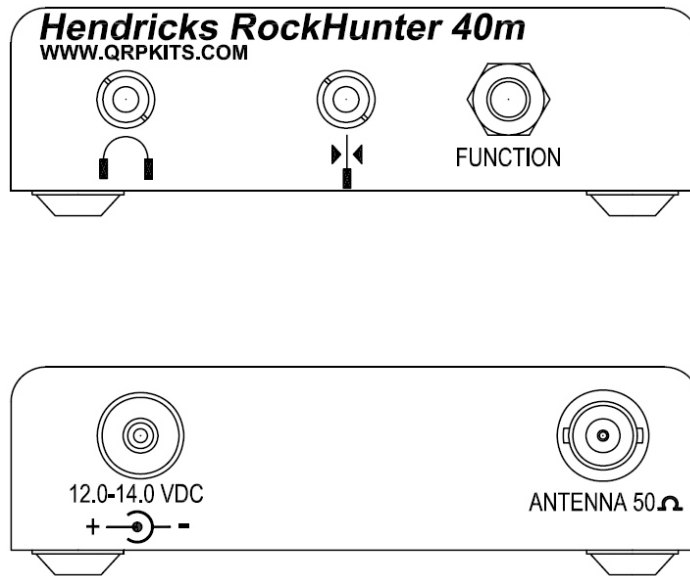

Thoroughly clean the surface of the panel to remove any oils or contamination. If you do not paint your case, we have found that moving the decals into position on a bare aluminum chassis is more difficult, due to the brushed surface, so we advise pre-coating the chassis with a light coating of the Krylon clear before applying the decals.

The decals are applied the same as model decals. Cut around each group of text you wish to apply. It doesn't have to be perfect as the background film is transparent. Apply the decals before you mount anything to the chassis. Use the above picture to get the correct spacing around the holes, as it is very easy to do a great decal installation and have a portion covered up with a knob.

Trim around the decal. After trimming, place the decal in a bowl of lukewarm water, with a small drop of dish soap to reduce the surface tension, for 10-15 seconds. Using tweezers, handle carefully to avoid tearing. Start to slide the decal off to the side of the backing paper, and place the unsupported edge of the decal close to the final location. Hold the edge of the decal against the panel, with your finger, and slide the paper out from under the decal. You can slide the decal around to the right position, as it will float slightly on the film of water. Use a knife point or something sharp to do this. When in position, hold the edge of the decal with your finger and gently squeegee excess water out from under the decal with a tissue or paper towel. Work from the center, to both sides. Remove any bubbles by blotting or wiping gently to the sides. Do this for each decal, and take your time. Allow to set overnight, or speed drying by placing near a fan for a few of hours. When dry, spray two **light** coats of matte finish, Krylon, clear to seal and protect the decals, and allow the spray to dry in between coats. All decals come with two complete sets, in case you mess one up.

Allow plenty of time for the clear spray to harden up, and continue as follows:

- Install the DP3T switch on the side of the PCB with the silk screening.

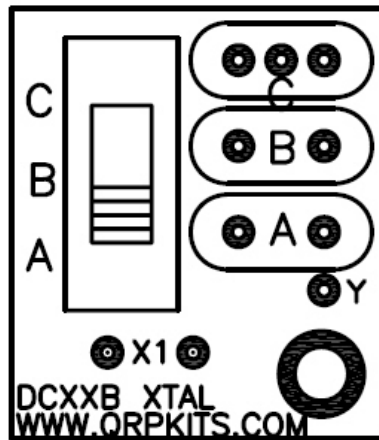

- Decide which frequency you want to be designated as “A” and “B”. Solder the crystals on the same side as the switch. Solder the 3 pin SIP strip into the “C” position.

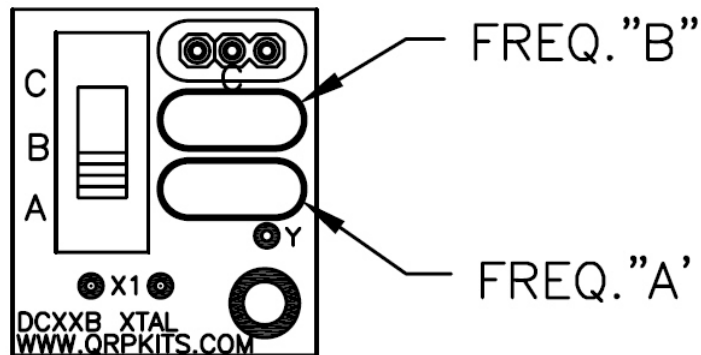

- It is common practice to tie all the crystal cases to ground. **Note: you may choose not to do this operation if you plan on changing crystals frequently.** Do not linger soldering the tinned wire to the crystal cases. The crystals are fairly tolerant, but they can be damaged by high prolonged heat. Cut a 2” piece of the supplied tinned wire.

After soldering the wire to the top of the crystals, the wire passing through the “Y” hole can be soldered and trimmed off flush on the far side.

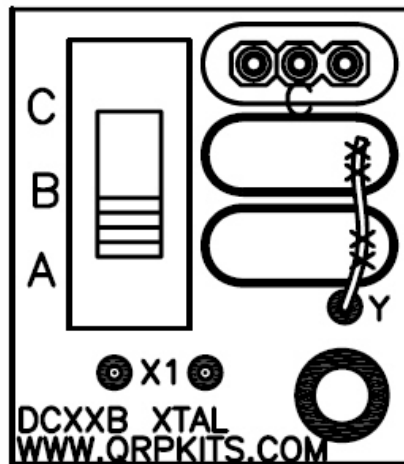

- If you installed one of the crystals, on the main board X1 position for testing, you will need to remove it now. Next you need to cut 2 pieces of the tinned wire, 3/4" long and solder them to the “X1” holes on the backside of the board, extending to the top of the board as shown. These leads will connect the expansion board to the X1 crystal position of the main board.

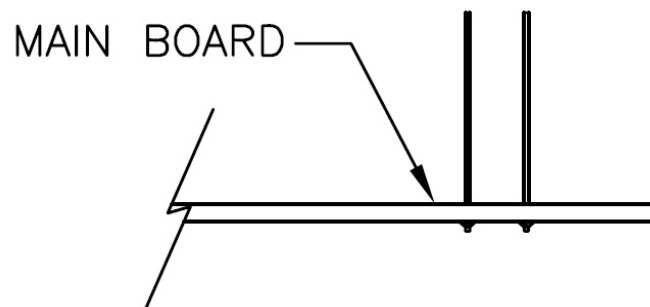

- Mounting of the expansion board to the main board is accomplished by first mounting the DCxxB board to the chassis and securing it with the three 1/4" 4-40 screws, leaving the front/right screw out. Slide the expansion board over the two X1 jumpers and secure the expansion board with the 3/4" long 4-40 screw with the 1/2" nylon spacer in between the two boards. Finally solder the two jumpers to the expansion board and trim flush with the top of the expansion board.

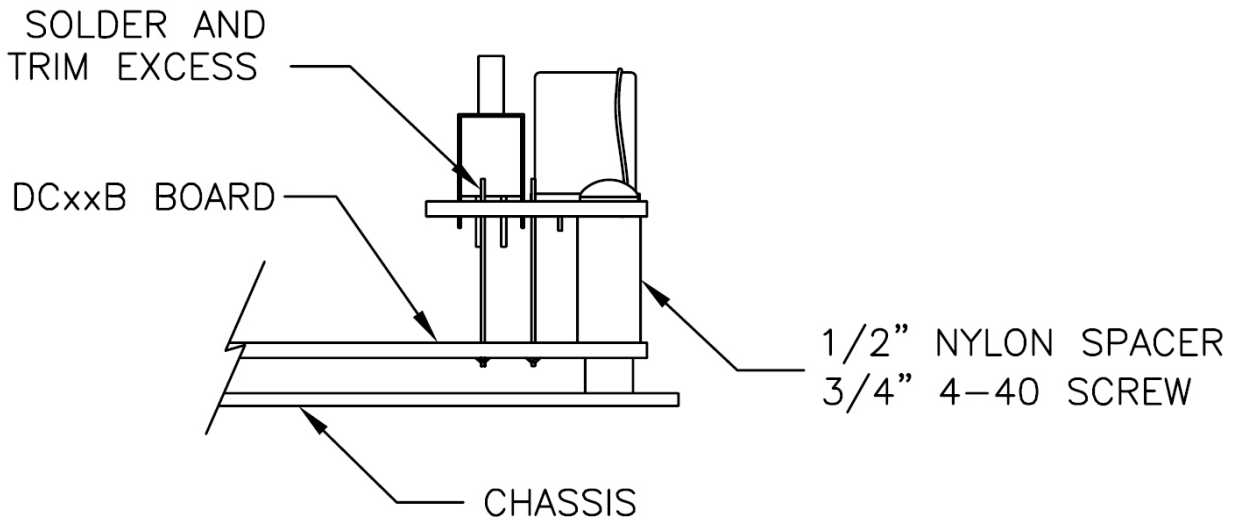

- You may now finish the interconnections from the main board to the connectors on the open chassis as shown below. Be sure to jumper the audio connector as shown so both sides of the earbuds will get sound.

