

# Pacific Antenna 80m SOTA Tuner

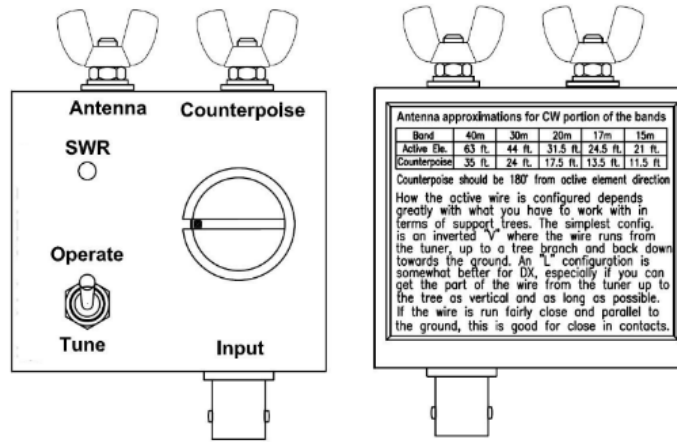

First, familiarize yourself with the parts and inventory the kit using the table below.

## Parts List

Inventory	Component	Quantity	Note
	SWR Indicator Kit	1	SWR Bridge Kit
	T94.2 toroid	1	Large red toroid core
	Polyvaricon	1	Variable Capacitor
	Polyvaricon shaft screw	1	2.6 x 12mm Phillips pan head screw
	Polyvaricon mounting screw	2	2.5 x 4mm screw
	Washers for mounting screws	2	Lockwashers for polyvaricon mounting screws
	Polyvaricon shaft	1	3/8" white Nylon standoff
	6-32 screw	2	3/4" Stainless phillips pan head screw
	#6 lock washer	2	Stainless
	#6 flat washer	2	Stainless
	6-32 wingnut	2	Stainless
	#6 nylon step washer	2	Nylon, white
	#8 nylon flat washer	2	Nylon, white
	#6 tinned solder lug	2	Solder Lug
	6-32 nut	2	Stainless
	4-40 screw	2	1/4" Undercut flat head
	BNC	1	Female, chassis mount
	1/4" shaft knob	1	Black plastic knob
	Magnet wire	72"	Red or Green #26 wire, 72 inches long
	Hook-up wire	18"	#22 or # 24 AWG, two colors, 9" each
	SOTA chassis	1	Aluminum, unfinished
	SOTA decal set	1	Waterslide decal sheet

### Assemble the SWR Indicator Kit.

Complete assembly instructions for the SWR indicator kit are located on-line at <http://www.qrpkits.com/swrindicator.html>.

The last component to solder to the SWR board is the LED. Use the above dimensions to locate the lip of the LED.

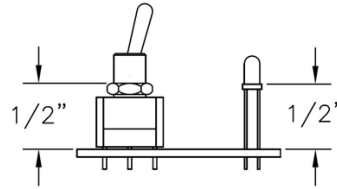

Adjust the inside nut of the switch, for the correct fit to the chassis so that the LED will just fit through the case when the SWR indicator is installed.

Set the SWR indicator aside, for now as the rest of the assembly is done inside the chassis.

### Prepare the chassis

Thoroughly clean the surface of the panel to remove any oils or contamination.

**TIP:** We have found that moving the decals into position on a bare aluminum chassis is sometimes difficult, due to the brushed surface, so we recommend either painting or pre-coating the chassis with Krylon clear, or a similar clear coating, and allowing the coating to thoroughly dry before applying the decals.

### Decal Application

The supplied decals are known as water slide decals. An example video of how to apply these types of decals can be found here: <https://www.youtube.com/watch?v=Pr5R9VCNVHU>

It is recommended to apply the decals before mounting anything to the chassis.

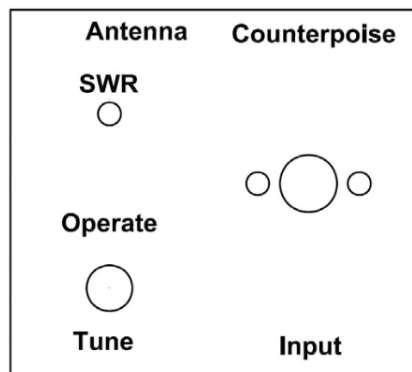

Use the above picture as a guide for the correct spacing of decals around the holes to prevent any labels being covered by a knob or switch.

Cut out and trim around each group of text or symbols you wish to apply. Trimming doesn't have to be perfect as the background film is transparent.

After trimming, place the decal in a bowl of lukewarm water with a small drop of dish soap to reduce the surface tension for 10-15 seconds.

Using tweezers, and carefully handle decals to avoid tearing. Start to slide the decal off to the side of the backing paper, and place the unsupported edge of the decal close to the final location.

Hold the edge of the decal against the panel, with your finger, and slide the paper out from under the decal. You can slide the decal around to the right position, as it will float slightly on the film of water. You may find it helpful to use a knife point or something sharp to do this.

When in position, hold the edge of the decal with your finger and gently squeegee excess water out from under the decal with a tissue or paper towel.

Working from the center, remove any bubbles by blotting or wiping gently to the sides. Take your time and do this for each decal.

Let the decals to dry overnight, and you can speed up this process by placing the chassis near a fan.

When completely dry, the decals should be sealed and protected by spraying at least two light coats of a clear matte finish, such as Krylon, or other similar products to. It is important to apply only light coats and to allow each coat to completely dry between applications

Once the final clear coat has dried thoroughly, continue as follows:

### Install the connectors and hardware on chassis

Assemble the two antenna connections and the bnc connector to the chassis cover.

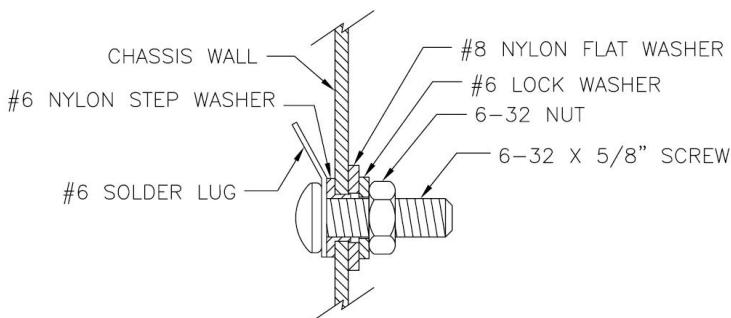

**NOTE:** The nylon step washers are used to keep the antenna connections insulated from the chassis.

Position the solder tabs as shown below, and angled down slightly, so that the antenna lug does not short against the PEM nut when the case is assembled.

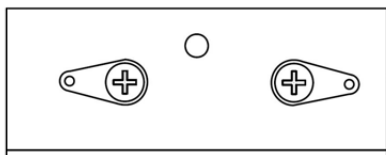

AS VIEWED FROM THE INSIDE

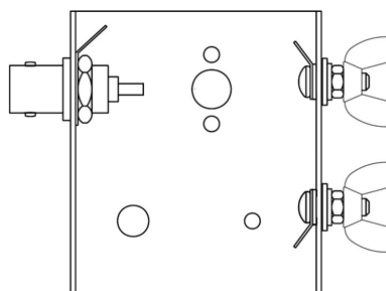

**Check** that there is no continuity between the solder tabs and the case at this point. This is to verify that the insulating washers were installed correctly.

## Wind L1

Use the T94-2 large red toroid and the enclosed magnet wire.

When complete, L1 will have a total of 49 turns, with a tap at 6 turns from the "START" end.

Remember, every time the wire passes through the center of the toroid, counts as one turn.

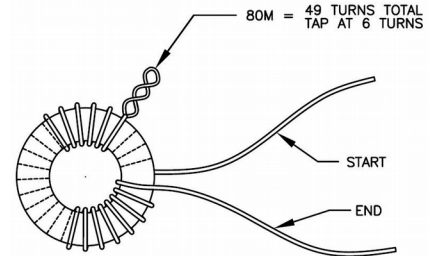

## Pre-wire the Poly-varicon

Wire as shown with 2" pieces of the hook-up wire, to the side shown.

Note that we are only using the 150pF side for 80m.

At this time, adjust the small trimmers on the back of the poly-varicon for half engagement.

At this time, adjust the small trimmers on the back of the polyvaricon for half engagement.

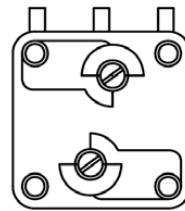

Mount the shaft and center screw provided on the polyvaricon



Cover the back of the poly-varicon with electrical tape. This will act as a surface to secure the toroid.

Wire the toroid to the poly-varicon as shown, and solder three pieces of 2" long hook-up wire as shown.

We will secure the toroid later with a couple of drops of hotmelt glue or adhesive. Mount the poly-varicon shaft with the screw provided

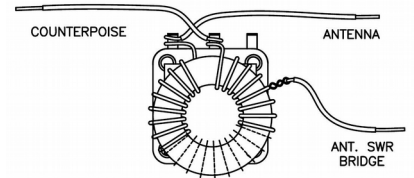

Wire only the two ends of the toroid winding to the poly-varicon as shown, Leave the tap unsoldered for now.

Pre-wire the previously assembled SWR indicator as shown with 3" long pieces of hook-up wire.

Install the pre-wired SWR indicator as shown here and secure it to the chassis with the remaining toggle switch nut.

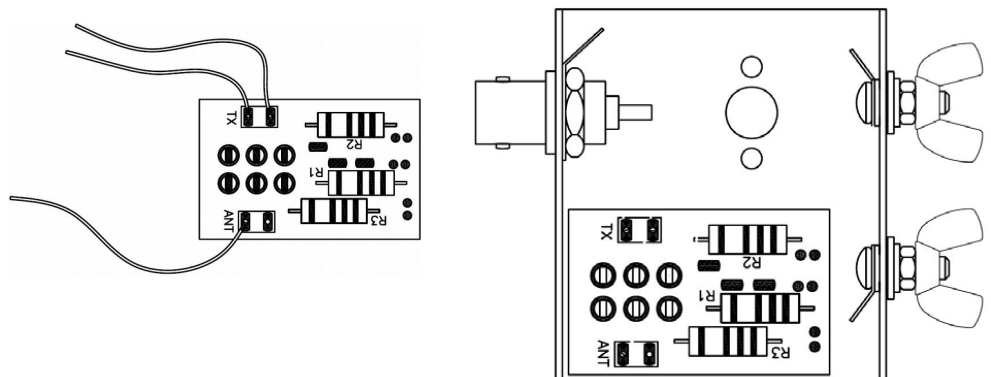

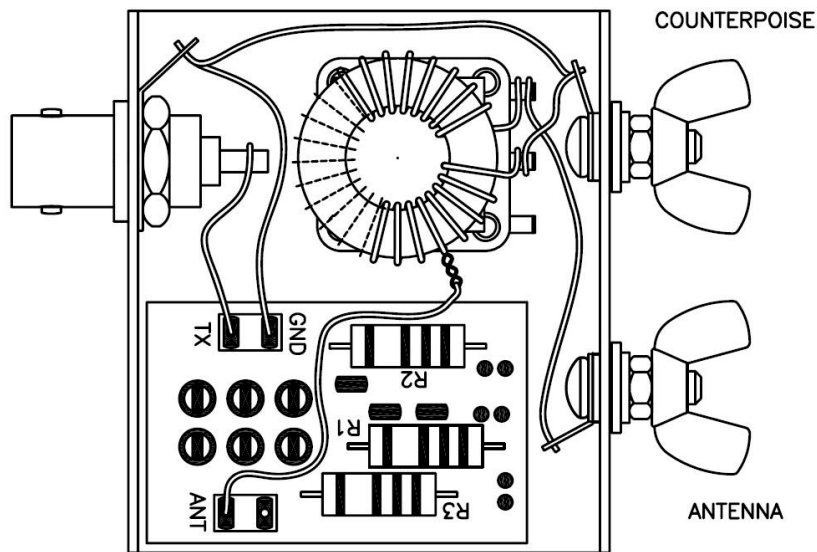

### Final Assembly Steps

The above diagram will assist with making the final connections to complete your SOTA tuner:

Mount the poly-varicon/toroid assembly to the chassis cover with the two 2.5 x 4 mm screws and the supplied lockwashers.

The washers are necessary to provide sufficient clearance for the polyvaricon plates. They are a relatively tight fit and may need to be gently pressed in place.

Solder the wire from the center connection of the poly-varicon to the counterpoise lug.

Solder the wire from the side connection of the poly-varicon to the antenna lug.

Solder the “ANT” wire from the swr indicator to the toroid tap.

Solder the “TX” wire from the swr indicator center connection of the BNC connector.

Solder the “GND” wire from the SWR indicator to the BNC ground lug.

**TIP:** Before proceeding test with the toggle switch in the “OPERATE” position to be sure there is no continuity between the wingnuts and the case.

Solder a wire from the BNC ground lug to the counterpoise ground lug.

Fit the bottom half of the case to the top and secure it with the two flat head 4-40 screws.

Install the knob on the poly-varicon shaft using the knob set screw.

**Congratulations this completes assembly of your SOTA Tuner!**

## Optional label for back of case

Band	40m	30m	20m	17m	15m
Active Ele.	63 ft.	44 ft.	31.5 ft.	24.5 ft.	21 ft.
Counterpoise	35 ft.	24 ft.	17.5 ft.	13.5 ft.	11.5 ft.

Counterpoise should be 180° from active element direction

How the active wire is configured depends greatly with what you have to work with in terms of support trees. The simplest config. is an inverted "V" where the wire runs from the tuner, up to a tree branch and back down towards the ground. An "L" configuration is somewhat better for DX, especially if you can get the part of the wire from the tuner up to the tree as vertical and as long as possible. If the wire is run fairly close and parallel to the ground, this is good for close in contacts.

Band	40m	30m	20m	17m	15m
Active Ele.	63 ft.	44 ft.	31.5 ft.	24.5 ft.	21 ft.
Counterpoise	35 ft.	24 ft.	17.5 ft.	13.5 ft.	11.5 ft.

Counterpoise should be 180° from active element direction

How the active wire is configured depends greatly with what you have to work with in terms of support trees. The simplest config. is an inverted "V" where the wire runs from the tuner, up to a tree branch and back down towards the ground. An "L" configuration is somewhat better for DX, especially if you can get the part of the wire from the tuner up to the tree as vertical and as long as possible. If the wire is run fairly close and parallel to the ground, this is good for close in contacts.

Band	40m	30m	20m	17m	15m
Active Ele.	63 ft.	44 ft.	31.5 ft.	24.5 ft.	21 ft.
Counterpoise	35 ft.	24 ft.	17.5 ft.	13.5 ft.	11.5 ft.

Counterpoise should be 180° from active element direction

How the active wire is configured depends greatly with what you have to work with in terms of support trees. The simplest config. is an inverted "V" where the wire runs from the tuner, up to a tree branch and back down towards the ground. An "L" configuration is somewhat better for DX, especially if you can get the part of the wire from the tuner up to the tree as vertical and as long as possible. If the wire is run fairly close and parallel to the ground, this is good for close in contacts.

If you want to have this chart on your tuner, print out the above labels and scale when printing as necessary to fit the bottom of the chassis.

Three sizes are provided to approximate the correct size to fit the case regardless of you printer scaling.

We recommend protecting this label with a piece of clear packaging tape, or peel and stick laminate film.

You can attach it to the back of the case with two-sided tape.

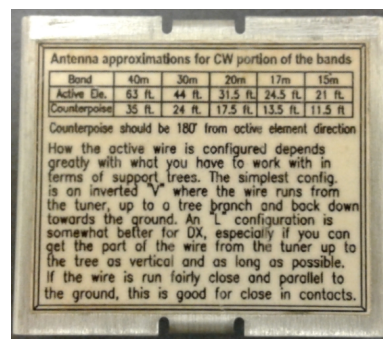

## Using your SOTA Tuner

Start with a light weight wire a few inches longer than the lengths suggested for the band you wish to operate and test to see if a good match can be achieved as indicated by the LED completely extinguishing as the tuning knob is turned over its range. If not, shorten the wire in one inch increments and retest.

**Note:** The values provided in the table above are suggested starting points, not absolutes and your wire lengths may vary due to many conditions.

**Note:** Some users use short counterpoises of approximately 0.1 wavelength successfully with endfed half wave antennas.

The condition and nature of the ground as well as the angle of elements in respect to ground, can all affect the overall length wire needed to achieve a good match.

We recommend that you test the SOTA tuner and note what works best for your conditions.

How the wire is deployed will depend on what is available for support such as trees and/or structures.

The simplest configuration is an inverted "V", where the active element runs from the antenna connection of the tuner, up to a tree branch, and back down towards the ground.

An "L" configuration for the active element is somewhat better for DX, especially if you can get the part of the wire from the tuner up as vertical as possible.

If the wire is run horizontally and fairly close to the ground, the signal will mostly be directed upward and therefore will be better for close in contacts, especially on the lower frequency bands.

Try to keep the counterpoise 180 degrees from the active element.



# Schematic

