

# The NADC

A CW rig using Nearly All Discrete Components  
Manual for 40 meter and 30 meter versions  
Hendricks QRP Kits  
[www.qrpkits.com](http://www.qrpkits.com)



Show with optional Digital Dial installed

## Specifications:

### Receiver:

Tuning range ~ 60 kHz  
Warm up drift – 10 minutes at room temp, ~ 100 Hz  
MSD (minimum detectable signal) ~ 0.25  $\mu$ V  
Band width, small signal ~ 400 Hz  
RIT range: - 2.5 kHz, + 1.1 kHz typical – range varies depending on operating frequency.  
Volume control with On/Off switch  
Receiver current, no signal ~ 23 ma  
With Digital Dial, ~ 45 ma  
Headphone level audio output

### Transmitter:

Power output: ~ 3 watts typical  
Spurs – 45 dBc  
Transmitter current: 600 ma  
PA efficiency, ~ 75% typical

Operating voltage range: 11.5 to 14 volts

Size: 6" wide, 4" deep, 1.5" high

Manual and circuit design copy write 2010 by Hendricks kits and KD1JV Designs

## Table of Contents

The NADC – Nearly All Discrete Components .....	3
A brief circuit description.....	3
The receiver.....	3
The VFO.....	4
RIT.....	4
The transmitter.....	4
Assembly:.....	5
Proper soldering:.....	5
Parts layout diagram.....	6
Ink Jet friendly / BW printer placement diagram:.....	7
Parts list.....	8
Installing the Resistors, molded inductors and diodes:.....	9
Installing the Capacitors:.....	10
Installing the Transistors:.....	11
Installing the Tall Parts:.....	11
Winding the toroid coils:.....	12
Time to inspect your workmanship!.....	13
Mounting U3, the 9 V regulator:.....	13
Installing U1 and U2:.....	13
Prepping the chassis.....	14
Chassis Wiring.....	15
Test and alignment.....	16
VFO frequency adjustment:.....	16
Peaking the Receiver coils:.....	16
BFO frequency adjustment.....	16
Peaking the transmitter band pass filter, T3 and T4:.....	17
Setting the IF offset in the Digital Dial.....	17
Final Power output adjustment:.....	17
Operating the rig.....	17
Okay, I built the rig and it doesn't work. What do I do now?.....	18
Trouble shooting steps:.....	18
Board track layout.....	20
Schematic 40 meter version.....	21

## The NADC – Nearly All Discrete Components

As the name implies, the NADC rig uses mostly discrete parts such as various flavors of transistors, diodes, resistors, capacitors and inductors. Only two integrated circuits are used, a SA612A for the first RF mixer and a LM386 for the audio amp. The use of MOSFETs in the transmitter PA results in high efficiency and therefore very little heat. Power output is about 3.5 watts. All the circuits, including the transmitter, run off a 9 volt regulator. Powering the transmitter power amplifier from the 9 volt regulator instead of the unregulated DC input supply insures consistent power output with changing supply voltages. However, this does limit the power supply to be at least 11.5 volts.

An optional Digital Dial can be added for a frequency readout. Although the digital dial uses mostly surface mounted parts (SMT), it is not hard to build and is a good first time SMT project to introduce you to building with these types of parts. If you do not already have a frequency counter, the Digital Dial will greatly aid in the initial setting of the VFO frequency.

### ***A brief circuit description***

Refer to schematic on last page to follow along.

### **The receiver**

Input signals from the antenna first pass through the transmitter low pass filter, then into a 2N7000 MOSFET (Q4) which is used as the QSK switch to disconnect the receiver input from the filter during transmit. The output of the QSK switch is connected to the receiver input tuned circuit, T1, a 10.7 MHz IF transformer, (40M version re-tuned to 7 MHz with C8). A SA612A mixer is used for the 1<sup>st</sup> mixer. Originally, a j-fet mixer was to be used here, but it did not provide enough conversion gain and the receiver was a bit on the “deaf” side, so the SA612A was used instead. This also simplified the circuit somewhat. R4 drops the 9 V supply voltage down to about 7.5 volts as the SA612A can not run directly on 9 volts. A capacitive divider, C18 and C11 lowers the VFO signal to the OSC input of the SA612A to an acceptable level for the chip.

The SA612A mixer output of 4.00 MHz is filtered by a three crystal IF filter. This provides good selectivity and adequate opposite side band image rejection. The filtered IF signal is now amplified by Q11, a 2N3904, before going into the product detector. The tuned side of the T2 IF transformer is used on the input of the product detector to provide some additional passive gain.

A pair of 2N3819 j-fets in cascode configuration to emulate a dual gate mosfet is used for the product detector. This configuration is a modified version of a RF mixer described in “Experimental Methods of RF Design”. RF mixer products and high frequency audio are by-passed to ground via C21, a 0.1 ufd cap. The BFO signal is supplied to the gate of Q5 via a crystal oscillator of Colpits configuration using Q2, another 2N3819 j-fet.

Another 2N3819 j-fet (Q10) is used for the audio muting, routing the audio output signal from the product detector through it. R15 keeps the gate biased on during receive and is pulled to ground to turn it off via Q15, a 2N7000 MOSFET.

The audio signal from the mute switch then goes into the top of the volume control pot, which in turns feeds the audio amplifier, a LM386. RF getting into this chip will affect it's operation, so the input is by-passed, along with the using an RF choke and by-pass cap on the output before going to the headphone jack.

Side tone during transmit is taken off the output of the product detector and feed into the second input of the LM386 via a resistor divider to provide volume control independent side tone level. Because of the strong signal the receiver sees during transmit, there is some distortion on the product detector output, resulting in a slightly raspy sounding side tone.

## The VFO

The VFO uses a j-fet in Colpits configuration. The VFO coil uses a large T68-7 core. The large physical size of the core provides thermal mass and the -7 material has the best thermal stability of the available powdered iron type toroidal cores. The low permeability of the -7 core results in needing a large C to L ratio. This all combines to result in a VFO with excellent stability. Most of the drift is caused by the RIT tuning diode, which has poor thermal stability.

## RIT

The RIT tuning diode, a 1N4756A zener diode, is coupled to the VFO tank circuit with a small value (10 pfd) NPO cap. Tuning voltage is supplied by the RIT control, a 100 K pot, which gets its operating voltage through two 1 K resistors connected to the ends of the control. These allow Q18, a 2N7000 MOSFET, to short out the control during transmit, centering the voltage on the tuning diode. RIT range is not linear in the plus and minus frequency direction, as the delta C of the tuning diode is not linear in respect to the voltage applied to it. The capacitance has a much larger change at lower voltages than it has at higher voltages.

RIT is turned off and the muting circuits are turned on during transmit by applying the transmitter keying voltage to the gate of Q18 through an isolating diode, D4. A R/C time constant on the gate of Q18 delays turning the mute off when going from transmit to receive in order to eliminate thumps and clicks in the headphones as the transmitter output ramps down and from glitches in the supply voltage.

## The transmitter

A single 2N3819 j-fet is used for the Tx mixer. The VFO signal is applied to the gate, which is buffered by taking the signal from the output oscillator pin of the SA612A. This prevents the VFO from shifting frequency when the Tx mixer is turned on with the transmitter is keyed. The heterodyne oscillator uses an NPN 2N3904 transistor instead of a j-fet here. It was found that using a j-fet here was very sluggish to turn on when keyed, preventing fast keying speeds.

The output of the Tx mixer is filtered by a band pass filter comprised of two IF transformers. The resulting 7 MHz (or 10 MHz) low level signal is then amplified by two stages of amplification. Three BS170 MOSFETs wired in parallel are used for the power amplifier. These require very little drive power, but do require a large voltage swing on the gate to fully turn on and work efficiently. By over driving the input of the driver stage, Q13 and driving the gates of the MOSFETs via the transformer T5, the gate drive signal is more of a pulse than a sine wave. This also improves efficiency by reducing the "on" time. A farther improvement in efficiency is achieved by using the output low pass filter to do some impedance matching to the 50 ohm antenna load. C7 across L7 forms a trap at the second harmonic of the transmitter frequency. This allows using a two inductor filter instead of a three inductor filter to get the required spectral purity on the output. This cap also has the additional benefit of increasing output power. All this results in a very good 75% PA efficiency. This is much better than the usual Class C amplifier of about 50% on a good day, but less than a Class E amplifier which can achieve close to 90%. Unfortunately, Class E amplifiers are much harder to get to work properly.

The down side of using a BS170 PA is that it is somewhat susceptible to high SWR. The 47 volt zener across the outputs helps prevent damage due to excessive voltage, since these only have a break down voltage of 60 volts. The real problem is that high SWR can cause the current in the BS170's to become excessive. Thankfully, by powering the PA from the 9 V regulator, the regulator is current protected so it can not deliver enough current to cause damage to the BS170's.

## Transmitter keying

The transmitter is keyed on and off using Q9, a PNP 2N3096 transistor. This switches power to the Tx mixer and driver circuits on and off. C36 connected to the base of Q9 makes the voltage to these circuits ramp up and down a little to help reduce key clicks from being transmitted, though the ramp up time is much faster than the ramp down time.

## Assembly:

- Please review all the assembly steps before you start. Although the assembly instructions are written with the first time kit builder in mind, we like to think your an intelligent person and with a little thought, can figure things out which might not be explicitly described in a drawn out, step-by-step manner.
- Before starting to assemble the board, you might want to skip ahead and prep the chassis. (See page 14) Getting this out of the way now will not delay you later when its time to install the board.
- Assembly instructions for the optional Digital Dial (DDial) are not included in this document. Down load assembly instructions from <http://www.qrpkits.com> web site. If you did purchase the digital dial, you might want to build that first, as it will be used for VFO alignment later.
- Although a lot of kit builders like to assemble and test a board in stages, this is not done with this kit. Due to the fairly tight parts layout, it is much easier to install the parts in the order of their relative height. This way tall parts do not get in the way of installing shorter, low profile parts like resistors and small capacitors. In addition, unless you happen to have an Oscilloscope and signal generator, very few sections of the circuit can be tested until it is completely built.

## Part numbering and their location on the board:

Parts are located on the board with ascending part numbers starting at the upper right hand corner of the board as shown in the diagrams, then right to left and zig-zag down. The board assembly can be sped up by presorting the parts into types and values, so you don't have to hunt through the pile of parts to find the ones needed at the time. Empty egg cartons are handy to organize parts and keep them from getting misplaced.

## Getting replacement parts:

Every effort is made to insure that the required parts and quantity are supplied with the kit. However, mistakes happen and you might be missing something, you could loose track of a part or damage one. Replacement parts can be had by sending an email to [parts@qrpkits.com](mailto:parts@qrpkits.com) and requesting that part(s). Be sure to make the subject line read "NADC replacement part request" and include your name and shipping address, as these will not be on record. It is also helpful if you specify the type and value of the part needed instead of just its board designation. If you just say you need R28, this will have to be looked up to see what value it is. Saying you need a 1 K resistor instead will speed up the process.

## Proper soldering:

The number one reason a kit does not work the first time you put power to it is for issues with soldering. The tip of your soldering iron needs to come in contact with both the lead you need to solder and to the solder pad on the board. Heat should be applied for about one second before flowing the solder into the connection. Solder should be feed from the side, or opposite from the tip of the iron. If you just cleaned the tip of the iron, you may have to touch a little solder to it in order to get good heat transfer to the lead and pad. Flow only enough solder to fill the hole and surround the lead. Many builders use way too much solder, leaving a large blob of it. Better control on the amount of solder used can be had by using 0.020" solder instead of the more common 0.032" size. The whole soldering operation should take no more than about 2 seconds, though ground locations or larger part leads can take a little more heat to get a proper connection. If it takes longer than this, your using an iron with too low a heat setting or wattage. The picture below on the right shows how proper solder connections should look and proper clipping of the part leads. The picture on the left illustrates how parts look from the top side of the board and can be used to help identify parts if you are not familiar with what different types look like.

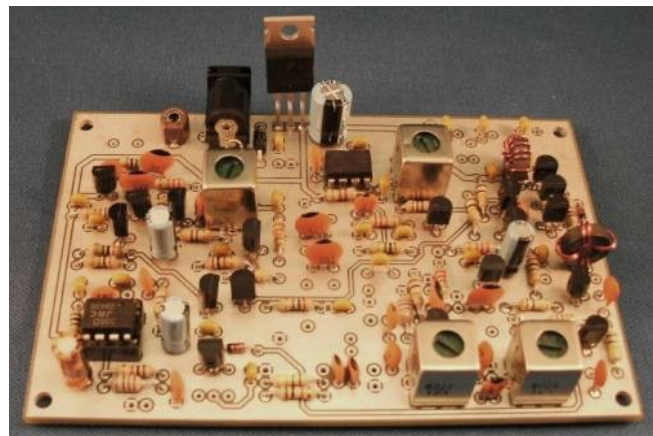
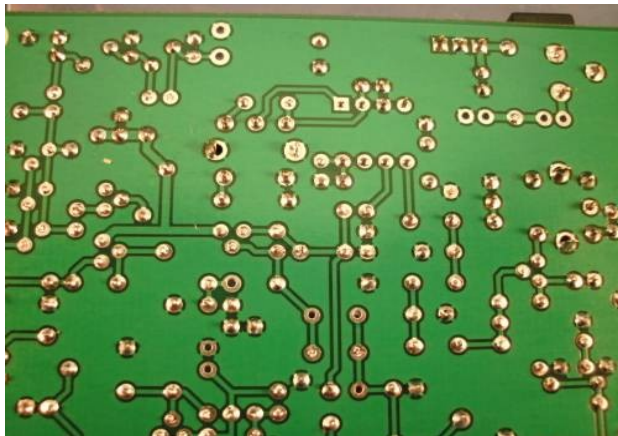

## Parts layout diagram

This color coded parts placement diagram with part values indicated will be used for locating the parts on the board and should be printed out for easy reference while building. For those who do not wish to use up a lot of their ink jet ink or have a back and white only printer, a placement diagram which has not been colored in is on the next page.

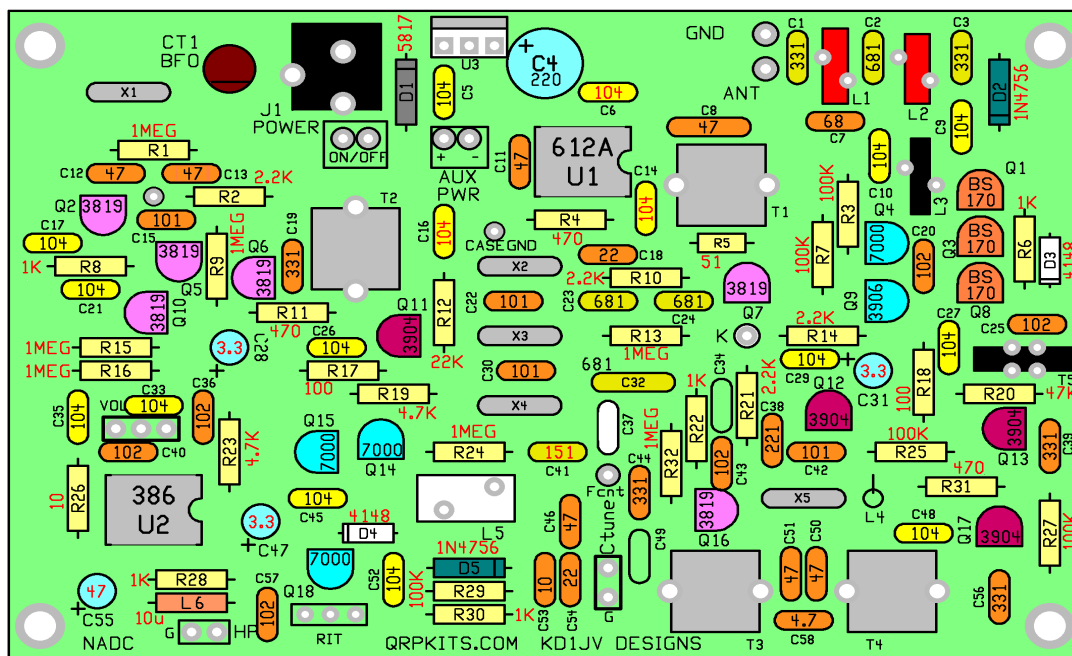

40 Meter version above

C49 not used, C37 VFO trim added during VFO alignment, L4 is replaced by jumper wire, R31 replaced by 3.9 uHy RFC

30 Meter version below

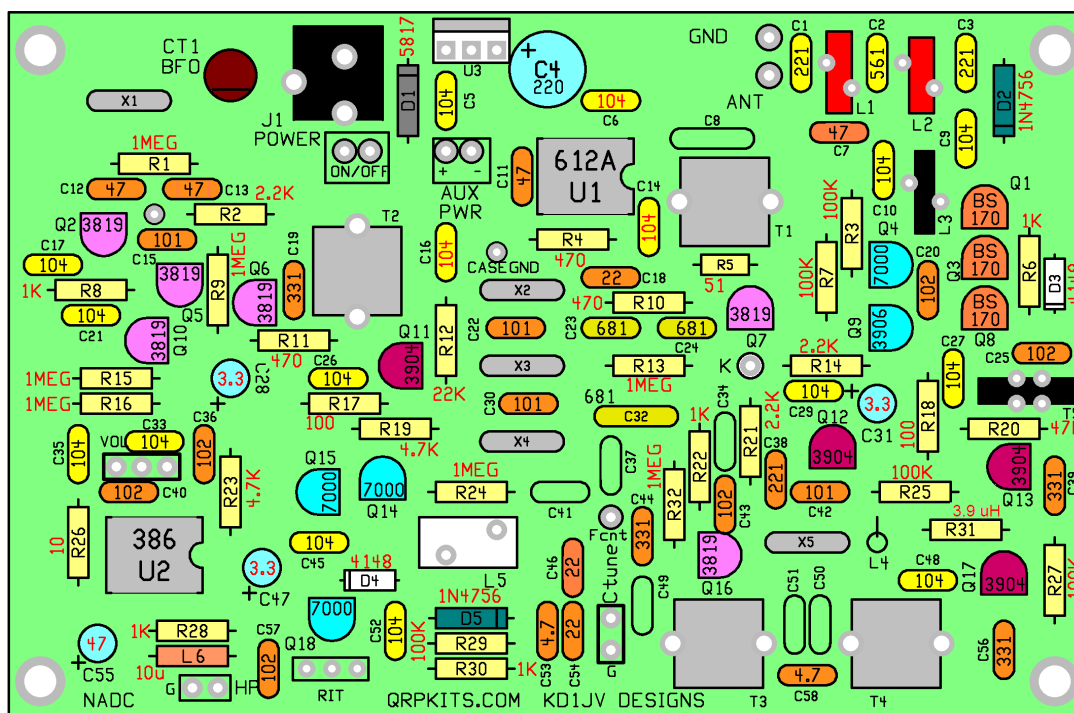

C8, C34, C37, C41, C49, C50, C51 not used. L4 replaced by jumper. R31 replaced by 3.9 uHy RFC.

# Ink Jet friendly / BW printer placement diagram:

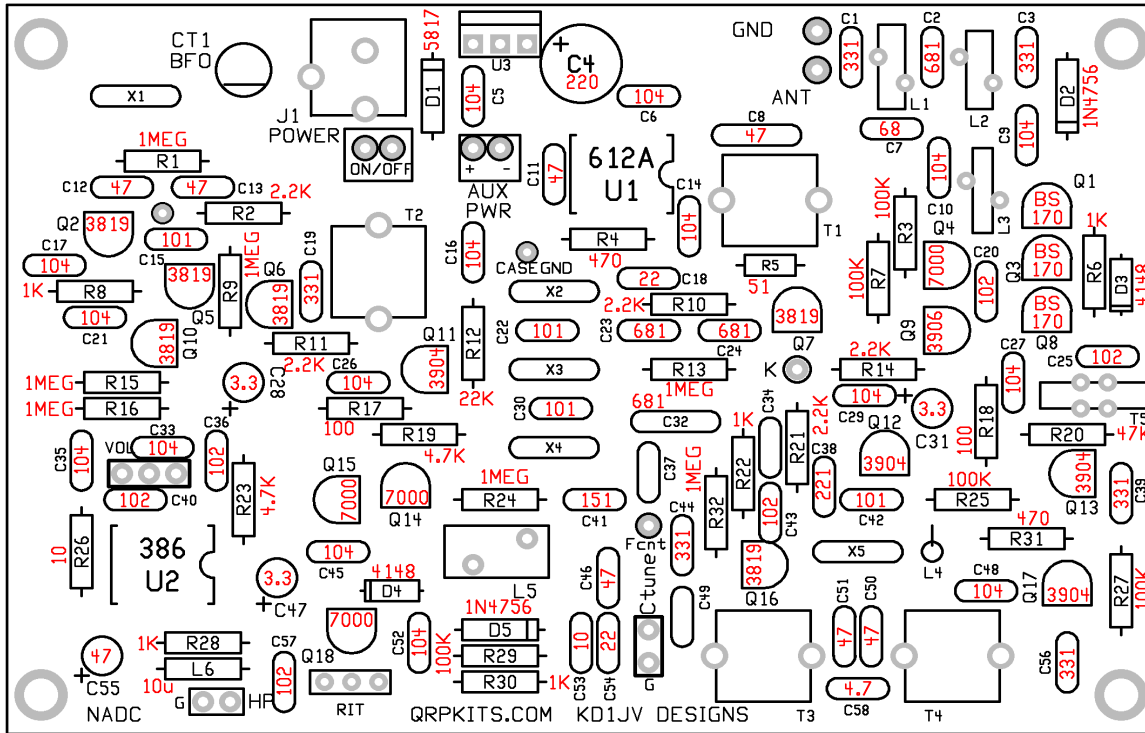

C49 not used, C37 VFO trim added during VFO alignment, L4 is replaced by jumper wire R31 changed to 3.9 uhy RFC

40 Meter version above, 30 meter version below

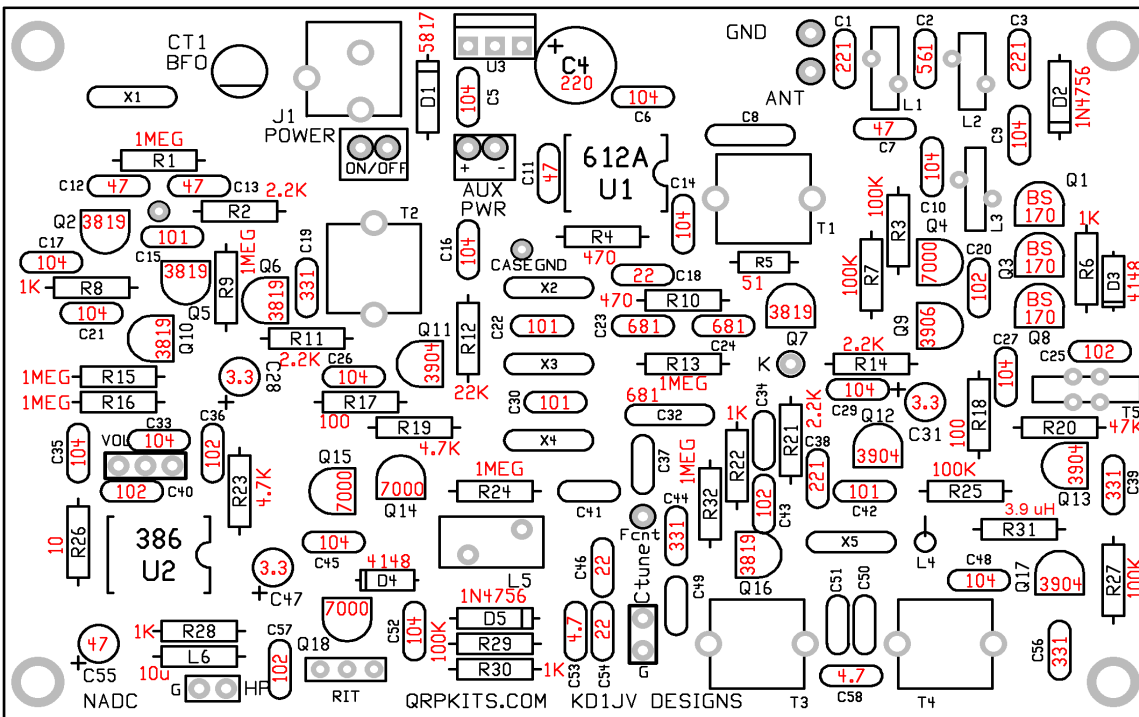

C8, C34, C37, C41, C49, C50, C51 not used. L4 replaced by jumper. R31 replaced by 3.9 uHy RFC.

**Parts list**

QTY	Value	Type	QTY	Value	
1	10 ohms	All ¼ Watt, 5% MF	1	2N3906	PNP
1	51 ohms		4	2N3904	NPN
2	100 ohms		6	2N3819	j-fet
2	470 ohms		4	2N7000	MOSFET
5	1 K ohms		3	BS170	MSOFET
4	2.2 K ohms		1	7809	9V regulator
2	4.7 K ohms		1	SA612A	Mixer/Osc
1	22 K ohms		1	LM386	Audio amp
1	47 K ohms		1	1N5817	Shottky diode
5	100 K ohms		2	1N4756A	47 V zener
7	1 MEG ohm		2	1N4148	Silicon small signal
1	10 K audio	Pot with switch	5	4.000 MHz	crystals
1	100 K linear	pot	4	10.7 MHz	IF cans
1	10 uHy	RFC	2	8 pin socket	
1	3.9 uHy	RFC			
1	Polyvariable	Tuning cap	1	T68-7	White
16	104	0.1 ufd Monolithic	2	T37-2 toroid	red
1	151	150 pfd C0G	2	FT37-43	Ferrite toroid
2	221	220 pfd C0G	1	Power jack	2.1mm pin
4	331	330 pfd C0G	1	BNC jack	
1	561	560 pfd C0G	1	Set of tuning cap	mounting hardware
4	681	681 pfd C0G	1	Large knob	
1	2.2	2.2 pfd disc NPO	2	Small knob	
2	4.7	4.7 pfd disc NPO	1	Case	top bottom
1	10	10 pfd disc NPO	1	Tilt stand bale	
2	22	22 pfd disc NPO	1	Tilt stand mounts	
7	47	47 pfd disc SL	4	Bumper feet	
1	68	68 pfd disc NPO	7	# 4-0.25 screw	
4	101	100 pfd disc NPO	5	# 4 lock washer	
1	221	221 pfd disk Y5P	1	# 4 nut	
4	331	330 pdf disc Y5P	1	Red display film	
6	102	.001 ufd disc Y5P	1	Set of decals	
1	50 pfd trimmer	Brown	1	3.5 feet # 26	Magnet wire
3	3.3 ufd /16V	Aluminum electrolytic	1	3 feet # 28	Magnet wire
1	47 ufd / 10V	Aluminum electrolytic	1	5 feet hook up wire	
1	220 ufd /10V	Aluminum electrolytic	1	Circuit board	
1	Stereo jack	3.5 mm	1	Mono jack	3.5 mm



## Installing the Resistors, molded inductors and diodes:

Assembly starts with the above parts, as these have the lowest height profile. All these parts should be mounted so that their bodies are flush to the board. After inserting the part leads into the holes in the board, you only need to kink the leads over to the side slightly to hold them in place. Laying the board down on a flat surface when you go to solder the leads helps insure the parts stay flush to the top of the board. To help speed up assembly, several parts can be inserted into the board before soldering them in place. Parts are listed in the order of ascending value and presorting the resistors in this order can also speed assembly and reduce chances of errors. If you don't know your resistor color code, the colors are listed in the table and in a chart at the bottom of this page.

√	Location	# places	Value	Color code	
	R26	1	10 ohms	BRN/BLK/BLK/GLD	
	R5	1	51 ohms	GRN/BRN/BLK/GLD	Do not mistake for 1 meg! (same colors, different order) bend leads close to body.
	R17, R18	2	100 ohms	BRN/BLK/BRN/GLD	
	R4, R11	2	470 ohms	YEL/VOL/BRN/GLD	
	R6, R8, R22, R28, R30	5	1 K ohms	BRN/BLK/RED/GLD	
	R2, R10, R14, R21	4	2.2 K ohms	RED/RED/RED/GLD	
	R19, R23	2	4.7 K ohms	YEL/VOL/RED/GLD	
	R12	1	22 K ohms	RED/RED/ORG/GLD	
	R20	1	47 K ohms	YEL/VOL/ORG/GLD	
	R3, R7, R25, R27, R29	5	100 K ohms	BRN/BLK/YEL/GLD	
	R1, R9, R13, R15, R16, R24, R32	7	1 MEG ohm	BRN/BLK/GRN/GLD	
	Molded Inductors:				
	L6	1	10 uHy	BRN/BLK/BLK/GLD	Note: this looks like a resistor, but is a little shorter and fatter.
	R31	1	3.9 uHy	ORG/WHT/GLD/GLD	R31 replaced by choke
	L4 (to the right of X5)		Wire jumper		Not used, replace with lead clipping wire.
	Diodes:				
	D1	1	1N5817	Black plastic	Note polarity line! Match the line around one end of the diode with line on diagram.
	D2, D5	2	1N4756A	Large glass body	Note polarity line!
	D3, D4	2	1N4148	Small glass body	Note polarity line!

### Resistor color chart.

First two colors indicate most significant decimal value, third color the number of following zeros. The last color is the tolerance. Gold being 5% and Silver 10%. One rarely sees 10% these days.

If gold or silver is used as the third color, this is a 0.1 (Gold) or 0.01 (silver) multiplier. In this way values of less than 10 ohms can be identified. A 5.6 ohm resistor will be marked Green, Blue, gold, gold for a 5% value.

This same color code value system is used for molded inductors.

Value	Color	abbreviation
0	Black	BLK
1	Brown	BRN
2	Red	RED
3	Orange	ORG
4	Yellow	YEL
5	Green	GRN
6	Blue	BLU
7	Violet	VOL
8	Gray	GRY
9	White	WHT

## Installing the Capacitors:

Next the small capacitors are installed. You may receive caps with lead spacing which do not fit the hole spacing. In this case, it usually means the leads are too far apart. Take a few minutes with your needle nose pliers to remove the kink in the lead so they fit properly and sit flush to the board. In a couple of places you may have to spread the leads a little for them to fit.

NOTE: you will end up with an extra 2.2 pfd and 4.7 pfd cap. These will be used for the C37 VFO frequency trim when you set the VFO frequency later.

Unique values for 40 meter version shown with blue background, 30 meter values with yellow background.

√	Location	QTY	Markings	Value / type
	C5, C6, C9, C10, C14, C16, C17, C21, C26, C27, C29, C33, C35, C45, C48, C52	16	104	0.1 ufd Monolithic
	[40M] C41	1	151	150 pfd C0G
	[40M] C1, C3	2	331	330 pfd C0G
	[40M] C2	1	681	681 pfd C0G
	[30M] C41	0	0	Not used
	[30M] C1, C3	2	221	220 pfd C0G
	[30M] C2	1	561	560 pfd C0G
	C23, C24, C32	3	681	681 pfd C0G
	C58	1	4.7	4.7 pfd disc NPO
	[40M] C53	1	10	10 pfd disc NPO
	[30M] C53	1	4.7	4.7 pfd disc NPO
	C18, C54	2	22	22 pfd disc NPO
	[40M] C8, C11, C12, C13, C46, C50, C51	7	47	47 pfd disc SL
	[30M] C11, C12, C13	4	47	47 pfd disc
	[30M] C8, C46, C50, C51	0	0	Not used
	[40M] C7	1	68	68 pfd disc NPO
	[30M] C7	1	47	47 pfd disk
	[40M] C46	1	47	47 pfd disk
	[30M] C46	1	22	22 pfd disk NPO
	C15, C22, C30, C42	4	101	100 pfd disc NPO
	C38	1	221	220 pfd disk Y5P
	C19, C39, C44, C56	4	331	330 pfd disc Y5P
	C20, C25, C36, C40, C43, C57	6	102	.001 ufd disc Y5P
	C34	0		Not used
	C37		TBD	VFO trim, select during test
	CT1 (BFO trimmer cap)	1	Brown	The flat edge of the part goes towards the line in the circle outlining the part location.

## Installing the Transistors:

We will now start installing the taller parts, starting with the transistors.

The one thing to be careful here is to identify the 2N3906 transistor. There is only one of these, but several 2N3904's and it is easy to mistake the two if you don't look carefully at the number on the part. The BS170's will need to have their leads reshaped to fit into the pad pattern on the board. And of course, the flat side of the part goes in the board facing the flat side of the part outline on the board. The bottom of the transistors should be spaced off the board by about 1/4" of an inch.

√	Location	QTY	Part Number / Type
	Q9	1	2N3906 PNP
	Q11, Q12, Q13, Q17	4	2N3904 NPN
	Q2, Q5, Q6, Q7, Q10, Q16	6	2N3819 j-fet
	Q4, Q14, Q15, Q18	4	2N7000 MOSFET
	Q1, Q3, Q8	3	BS170 MSOFET

## Installing the Tall Parts:

Now to finish up by installing the larger and tallest parts.

√	Location	Type	
	U1, U2	8 pin socket	Face the socket so that the notch on one end is above the notch shown on the part outline on the board. Make sure all the leads make it through the holes in the board, as removing the socket if a lead bends under it after some pins have been soldered is very difficult with out damage to the board or socket.
	T1, T2, T3, T4	IF transformer	The mounting taps should be soldered and will take some heat to do so.
	J1	Power Jack	There is some slop in the mounting holes, push the jack back as far as it will go, but make sure it is square to the edge of the board and sits flat onto the board.
	X1, X2, X3, X4, X5	Crystals 4.000 MHz.	The case of X2, X3 and X4 should be grounded. Put a piece of lead clipping in the hole labeled "case ground" and solder. Solder the other end to the top edge of X2. The use another piece of lead clipping placed along the top of these three crystals to connect them together. First running a file along the edge of the crystal case can help with getting the solder to stick. The case of X1 and X5 do not need to be grounded.
	C28, C31, C47	3.3 ufd /16V	Aluminum electrolytic capacitor. Note that these have polarity and must be properly orientated. The long lead is the + and the – lead is marked by a black line along the side of the case
	C55	47 ufd / 10V	Observe polarity as above.
	C4	220 ufd / 10V	<b>NOTE:</b> tilt body of cap slightly to right in order to clear regulator to be installed later.

You will note that we haven't installed the 9V regulator U3 yet. This will be done last, as you need to mount the board in the case to get the mounting hole to line up correctly before soldering it in place. But before we do that, we need to wind and install the toroidal coils. This is described in detail on the next page.

## Winding the toroid coils:

This is a task some builders don't like, but it is pretty easy. The wire should be wound snug to the sides of the core and conform the outline of the core. But don't try to wind the wire too tight and it is not really possible to get the wire to sit flat on the outside and inside surfaces of the core. If the wire is wound too loosely, not only will it look bad, but performance will be degraded. In the case of L1 and L2, power output will be affected and in the case of L5, the VFO coil, stability will suffer.

When counting turns, remember one turn is each time the wire passes through the center of the core. Having the proper number of turns on L1 and L2 is imperative for getting proper power output and signal purity. The turns should be more or less evenly spaced around the core, with a bit of a gap between the start and finish end.

If you wind the cores by passing a short length of the wire into the center of the core from the top as you hold it in your left hand, (this is turn #1, don't forget to count it as such) then pass the long end of the wire up from the bottom side, like you would when making a stitch with needle and thread, the ends of the wires will line up properly with the staggered holes in the board for where they mount.

The magnet wire supplied can be tinned directly with the soldering iron, but this must be done before the wire is inserted into the holes in the board. A little blob of solder on the tip of the iron helps, along with some rubbing action. If your iron isn't hot enough to melt through the insulation, scrape it off with a knife.

√	Core type	# of turns	# of turns	Notes
		40 meter	30 meter	
L1	T37-2 RED	19	16	#28 wire 12"
L2	T37-2 RED	17	12	#28 wire 11"
L3	FT37-43 Black	10	10	#28 wire 8"
L5	T68-7 White	34 30"	21	#26 wire – this is slightly thicker than the #28. Stretching this wire slightly before winding by grabbing both ends with some pliers, then giving it a firm tug can improve VFO stability.

Properly wound coils should look like the picture below:



## Winding T5.

4 turns of 2 parallel wires on FT37-43 core (black) #28, 7" total, 3.5" folded in half.

This core is wound with equal turns of two parallel wires. This is most easily done by folding a length of wire in half before winding, then wind the required four (4) turns. Once wound, snip the wire at the bend to separate the wire to form two windings. The wires must now be orientated so that the common ends are opposite each other on each side of the core. We can call the ends of each wire A – A' and B – B' See diagram. For clarity, the wires are shown as two different colors.

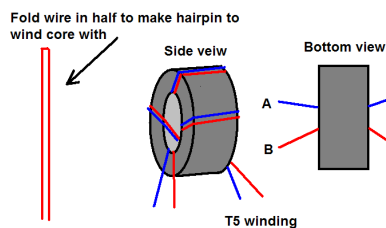

Once wound and the leads tinned, mount the coil into the T5 location so that the wire ends A-A' and B-B' are in the hole pattern shown in the diagram to the right. It does not matter which wire you call A or B, it is just important that there is continuity between the ends of the wires opposite (in line as seen from the side) of each other and not diagonally.

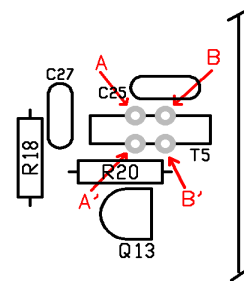

## Time to inspect your workmanship!

There is only one part left to install, the 9V regulator, but before you do, this is a good time to inspect your work. Double check the parts for being in the proper locations and most importantly, your soldering. Look for any connections you may have forgotten to make (this can happen if you put several parts in place before soldering any of them), solder bridges or solder splashes which can make shorts between places which shouldn't be connected together. Solder which bridges between two adjacent pads is likely a short.

Cleaning off any flux residue can aid in inspecting the solder connections, though this is not required. If you do wish to clean off the flux, I find CRC QD Electronic Cleaner available at Wal-Mart in the automotive chemical section to work well. Use an old (but clean) tooth brush to scrub the bottom of the board. As the fumes from this product are nasty, do it outside.

### ***Mounting U3, the 9 V regulator:***

First, mount the board into the bottom of the case. Insert the regulator into the holes in the board and bend the leads as required to make the mounting hole line up with the hole in the back of the case. Bend the narrow section of the leads. Do not bend them close to the body of the part, or they may break off. The metal tab on the regulator does not need to be insulated, as it is at ground.

Tack solder one the of the leads to the board to keep the part in place (from the top side, being careful not to touch C4 or the power jack with the side of the soldering iron). Then remove the board and solder the leads from the bottom of the board.

### **Installing U1 and U2:**

Finish up by inserting U1 (SA612A) and U2 (LM386) into their respective sockets. You will need to bend the leads slightly in towards the body of the chip for the leads to go into the socket. This best done by placing the side of the leads on a flat surface (your work bench) and rotating the body slightly.

**Important!** The IC can go into the socket one of two ways. One way is correct and the other isn't. There is a notch or dot on the Pin 1 end of the IC which corresponds to the notch in the part outline. The IC must be installed facing this direction. If the IC socket was installed correctly, the notch on the socket end should be in the correct direction. No big deal if it isn't, just make sure the IC goes in the correct direction.

- The board assembly is now complete.
- Proceed to prepping the chassis before mounting the front panel controls and wiring up the board, as described on the following page.

## Prepping the chassis

Before mounting the front panel controls and wiring the board into the case, it is time to prep the case by painting it if you like and attaching the decal labels. Since the lettering on the decals is black, if you do paint the chassis, be sure to use a light color.

The decals are applied in the same manor as model decals. Cut around each group of text or symbols you wish to apply. It doesn't have to be perfect as the background film is transparent. Use the diagrams below as guide for where the decals go. Be sure to get the correct spacing away from the holes, as it is very easy to do a great decal installation and have a portion covered up with a knob.

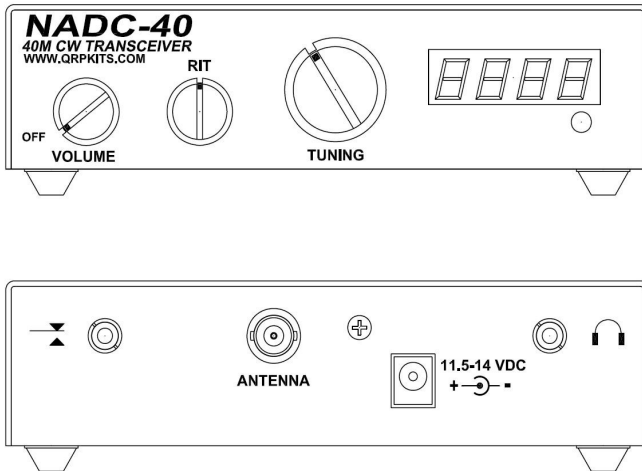

**Thoroughly clean the surface of the panel to remove any oils or contamination. Use dish washing liquid soap and water (rise well), denatured alcohol or paint thinner. We have found that moving the decals into position on bare aluminum chassis is difficult, due to the brushed surface, so we advise pre-coating the chassis with the Krylon clear before applying the decals. (Unless you have elected to paint the chassis first).**

Trim around the decal. After trimming, place the decal in a bowl of lukewarm water, with a small drop of dish soap to reduce the surface tension, for 10-15 seconds. Using tweezers, handle carefully to avoid tearing. Start to slide the decal off to the side of the backing paper, and place the unsupported edge of the decal close to the final location. Hold the edge of the decal against the panel, with your finger, and slide the paper out from under the decal. You can slide the decal around to the right position, as it will float slightly on the film of water. Use a knife point or something sharp to do this. When in position, hold the edge of the decal with your finger and gently squeegee excess water out from under the decal with a tissue or paper towel. Work from the center, to both sides. Remove any bubbles by blotting or wiping gently to the sides. Do this for each decal, and take your time. Allow to set overnight, or speed drying by placing near a fan for a few of hours. When dry, spray two **light** coats of matte finish, Krylon, clear to seal and protect the decals, and allow to dry in between coats. All decals come with two complete sets, in case you mess one up.

- Once the overcoat is dry, proceed to installing the front panel controls and wire up the board as described on the following page.

## Chassis Wiring

Install the front panel parts in to the chassis - the volume control, RIT control and tuning cap. The chassis is shown folded flat for clarity. Tape the red film over the display cut out, placing the tape along the least amount of the edges of the film as possible. This is used if a digital dial is installed or not, as you need something to cover the cut out if it isn't. The corners of the film may have to be trimmed to clear the mounting studs. The wire lengths listed in the table below should be long enough to give you some slack. It is a good idea to have a short "service loop" at the end of the wire as not to have strain on it.

Volume control	3"	Headphone jack	4"	Digital Dial power	6"	On/Off	5"
RIT control	2.5"	Key Jack	4"	Tuning cap	1.5"	Antenna jack	1.5"

Connect the wires to the board first. Wires going to the on/off switch, volume control, straight key jack and Digital Dial power should be connected from the bottom of the board and routed under the board to their respective parts. The remaining wires connect from the top of the board. Now install the board into the chassis and connect the appropriate wires to the various controls and jacks, as show in the diagram below. Wires to the D Dial are best connected to it before you mount it in the chassis.

- Ground wires are shown in Brown.
- Supply wires are shown in Red.
- Signal wires are shown in Blue.

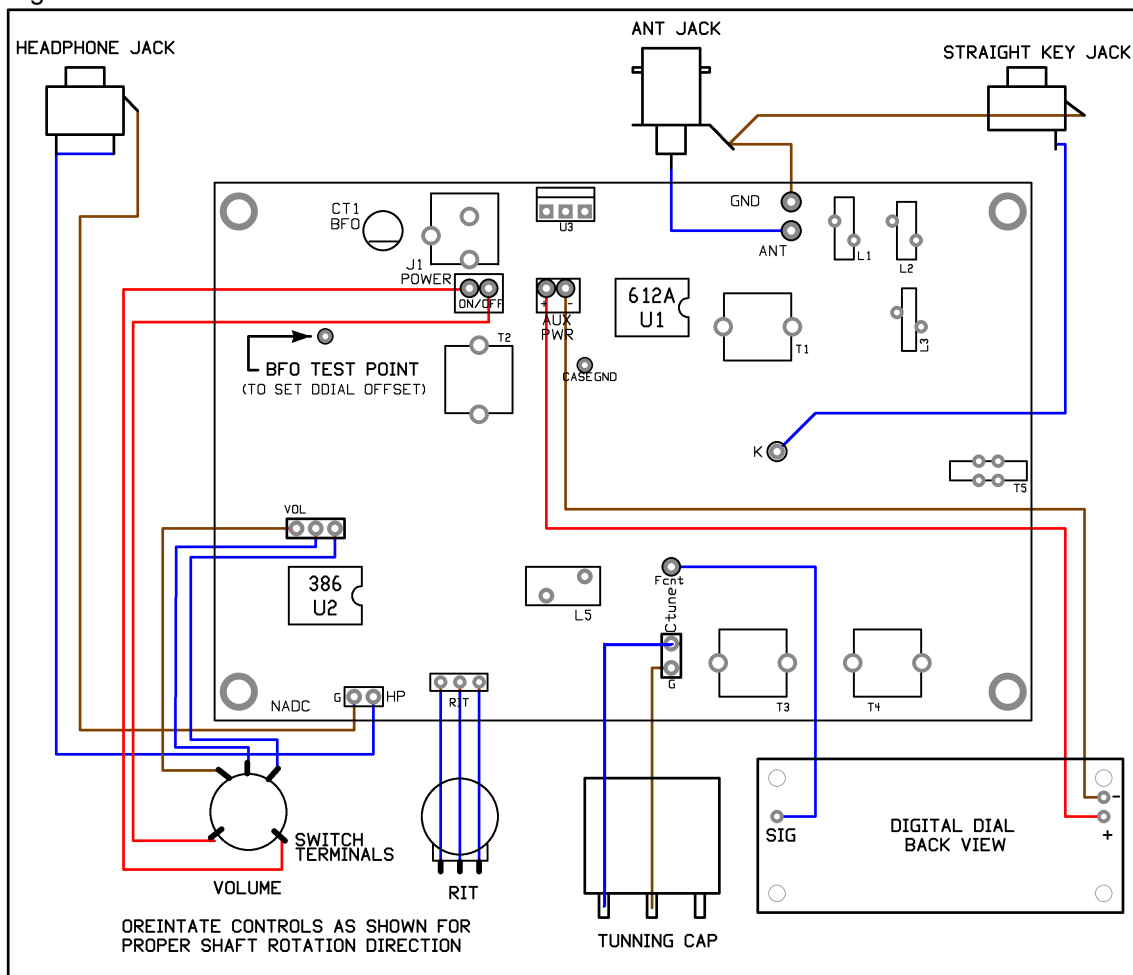

## Attaching the knob to the tuning cap

Since the tuning cap does not come with a shaft for a knob to attach to, one is made from the long Nylon spacer and screw.

## Test and alignment

### ***VFO frequency adjustment:***

The first step in getting the rig on the air is to set the VFO frequency. This is most easily done with a frequency counter, though a general coverage receiver could be used instead.

[40 M] The frequency of the VFO will likely be a little on the high side for most users. With the tuning cap wired in and set for maximum capacitance (turned fully counter clock wise) and the wire of the VFO coil (L5) more or less evenly distributed around the core, the initial VFO frequency should be somewhere around 3.05 MHz.

The frequency can be adjusted in two ways. For coarse adjustment, add a 2.2 or 4.7 pfd cap in the C38 location to lower the frequency into the general area you wish for a minimum frequency. For fine adjustments, change the spacing of the wire on the L5 coil. Moving turns closer together will reduce the frequency. Setting the frequency so that it is about 3.005 MHz insures you do not tune below the band and allows tuning of the most popular segment of the CW sub-band.

[30M] The frequency of the VFO will likely be a little on the high side for most users. With the tuning cap wired in and set for maximum capacitance (turned fully counter clock wise) and the wire of the VFO coil (L5) more or less evenly distributed around the core, the initial VFO frequency should be somewhere around 6 MHz.

The frequency is adjusted by change the spacing of the wire on the L5, VFO coil. Moving the turns closer together will reduce the frequency. You will usually only have to move one or two of the turns. Set the frequency so that it is as close to 6.100 MHz as possible. Note that placing the cover on the rig will shift the frequency upwards by a couple of kHz.

Once the VFO frequency has been set, it is a good idea to secure the coil to the board to reduce micro phonic effects. A little dab of hot glue at the base of the coil to the board will do the trick. You may also desire to secure the wire to the core by "painting" it with nail polish. You can also melt a layer of wax on the coil, using a low heat heat gun or embossing gun. This can be messy if your not careful. Shielding the area around the core with some paper can help keep the wax from running all over the place.

### ***Peaking the Receiver coils:***

Now that the tuning range of the VFO has been set, you can now peak the two IF cans in the receiver section. The slugs in T2 and T1 will need to be turned into the can to peak them from the factory setting. (clockwise). Plug in your headphones and connect an antenna. First adjust the T2 slug for maximum band noise, hiss or a signal. Now tune until you do hear a signal and do the same for T1. The peaking of T2 will be fairly sharp, while T1 will be somewhat broad.

### ***BFO frequency adjustment***

The BFO frequency needs to be set so it produces about a 600 Hz beat note when an input signal is centered in the pass band of the IF filter. The best way to do this is with the aid of your PC running a PSK program such as Digipan. By connecting the audio output of the NADC rig via the headphone jack into the mic jack of your PC and running Digipan, you can see the response of the receiver in the waterfall. If the band is noisy, as it generally is, you will see the noise on the waterfall. Adjust the BFO trimmer, CT1, so this noise is centered at about the 600 Hz tick on the frequency ruler.



### **Peaking the transmitter band pass filter, T3 and T4:**

Disconnect the antenna and connect a watt meter and dummy load to the antenna jack. Do not use an antenna. Until the filter is adjusted, spurious signals can be transmitted, resulting in high SWR and possible damage to the power output amplifier.

Ideally, the watt meter you use should be of a QRP type with a full scale of 5 watts. This will allow the most accurate adjustment. It will be difficult to see the best peak on a meter with a 100 watt scale! If you don't own a suitable 50 ohm dummy load and watt meter, the Hendricks Kits Dummy load kit would be worth getting. It includes a RF voltage detector diode which can be used to peak the transmitter filter coils.

Set the VFO frequency to the center of the tuning range. This will ensure the most consistent power output over the tuning range and the cleanest signal at the tuning extremes. Preset the slugs in T3 and T4 fully clockwise into the can.

With 40 meter version, It is possible to peak the filter to the second harmonic of the transmitter's heterodyne crystal oscillator operating at 4 MHz. This of course results in an 8 MHz signal which for the most part will be attenuated by the low pass filter on the transmitter output. You know if your peaking at the real transmit frequency if you can hear the side tone in the headphones.

Key the transmitter and back out the slugs in T3, then T4 about a ¼ turn at a time until you start to see power output. The tuning of T3 will be fairly sharp, while T4 no so much. Once you start to see power output, slowly adjust T3 and T4, working back and forth between them a little at a time until you see the most power output, which should be about 3 watts.

### **Setting the IF offset in the Digital Dial**

The Digital Dial needs to know the BFO frequency in order to display the operating frequency correctly. This is done by connecting the signal input of the D Dial to the BFO test point shown on the chassis wiring diagram on page 15, then following the instruction for the D Dial. LO offset Mode A will be used, VFO + LO.

However, this will result in the frequency display being about 600 Hz high, since the D Dial does not correct the for BFO beat note offset. The BFO trimmer cap CT1 can be shorted out (you will need to remove the board from the case to do this) to lower the BFO frequency and bring it more in line with the transmitter Heterodyne oscillator frequency.

### **Final Power output adjustment:**

Power output is very sensitive to the way the wires on L6 and L7 are spaced on the cores. With a little "tweaking" of the wire spacing, you should be able to achieve the full 3.5 watts out, or even a little more. However, going above 3.5 watts will result in higher transmit current and less PA efficiency, so staying in the 3 to 3.5 watt range is recommended. In general, spreading the spacing of the turns on the L2 core will increase power output. Moving the turns on L1 closer together will also increase power output. This only has to be done to a few of the turns, use the ones near the top of the coil, as these are the easiest to reach.

### **Operating the rig**

- Make sure you keep the RIT centered. If you have the optional digital dial installed, you will see the frequency change when transmitting if it isn't.
- The side tone will sound a little raspy, due to distortion in the product detector. If the side tone isn't loud enough for you, increasing the value of R23 from 4.7K to something larger like 10K will solve that.
- The side tone may not match the tone the receiver peaks at due to variations in the Tx heterodyne oscillator frequency. The difference shouldn't any more than 100 to 200 Hz at worse, which is better than some simple QRP rigs. RIT is included to compensate for this error. If stations consistently come back to you a little higher or lower in frequency, keep the RIT set to compensate.

- High SWR loads should be avoided! The PA can operate into an open circuit with no trouble and a short circuit for a short time, but highly reactive loads causing high SWR may cause damage. If an antenna tuner is needed, using a resistive bridge SWR detector for adjusting the tuner is recommended. A SWR bridge of this type is also available from qrpkits.com.

## Okay, I built the rig and it doesn't work. What do I do now?

So far we have assumed you did a proper job of assembly and everything worked just fine the first time power was applied. Unfortunately, this is sometimes not the case. So, now it's time to drag out the test equipment and do some trouble shooting. For most builders, this will mean just a DVM. Having or having access to a signal generator and Scope makes the process so much easier.

As noted at the beginning of the assembly section, the most common reason a kit does not work is due to soldering issues. The solder masked board reduces the chances of making solder shorts between pads which should not be connected together, but does not completely eliminate that chance. If solder is bridging between any adjacent pads, it is most likely a short which does not belong there. Also look for any connection you might have missed making. One common problem is not doing a good job tining the magnet wire on the toroids so there is no connection being made.

The chances of getting a defective part is very slim. It is however, very possible a part can be damaged if it is not installed correctly or miss handled. The 2N7000 and BS170 MOSFET transistors can be subject to damage from static while handling. Simply assuming you have a bad part and replacing it rarely fixes the problem, since it is more likely to be a soldering or assembly problem.

If you do need to replace a part, once it is removed you have to clean the solder out of the hole to get the new one in. A solder sucker works best for this, as solder wick often doesn't do the job. Often you will actually have to add solder to the hole for it all to come out.

*If you need to remove the board from the case to work on it, it is a good idea to disconnect the wires to the tuning cap, as the leads on cap can break off easily when flexed a few times.*

### ***Trouble shooting steps:***

The chances are good most every thing is working properly and there are only one or two problem areas. What needs to be done is to identify what is not working. This is a step by step procedure and a process of elimination. Figure out what is working to locate that which is not.

The schematic has DC and AC voltages labeled at various points in the circuit for reference. The AC volts were measured with an Oscilloscope and are the peak to peak voltage. Some of the DC measurement points have an RF signal on them and exactly how your DVM responds to this condition may be different than the way the meter used to measure these voltages did. Only be concerned if the the voltage you measure is significantly different that that which is indicated, some variation is to be expected.

1. Is there power going to the circuits? Make sure the supply voltage is getting to the input of the 9 volt regulator. Some reasons it might not be are D1 is installed backwards, the on/off switch is damaged and not working, your using the wrong size power plug, like one for a 2.5 mm pin instead of a 2.1 mm pin.
2. Is there 9 volts coming out of the regulator? If not, there is a short from the output pin to ground somewhere. It could be right at the regulator, but could be anywhere on the board.
3. Is the VFO and BFO oscillators working and is the VFO on the right frequency? If you don't have a frequency counter, use a general coverage receiver. A short clip lead antenna will be needed, so you can put it close to these areas to pick up a signal.
4. The audio amp can be tested by putting a finger on the parts in that area and listening for hum pickup.
5. The SA612A mixer, IF amp and product detector can not be easily tested without a signal generator and Scope. If you don't have these, about all you can do is check the voltages to see if there is a problem in those areas.
6. No transmit – Having a Scope makes tracking the signal through the transmitter stages easy and a

DVM isn't going to be a lot of help. Make sure Q9 is turning on and powering the mixer/driver stages and that the wires on T4 are in the correct locations, L3 is properly soldered in and you remembered to install a jumper wire in the L4 location .

### **Getting help**

Hendricks Kits, aka qrpkits.com does not supply technical support directly. Replacement parts will have to come from Doug, but technical help is provided by Steve, KD1JV email to [steve.kd1jv@gmail.com](mailto:steve.kd1jv@gmail.com)

The more specific you can make your question, the better the answer which can be supplied. If you simply say it doesn't work, that does not give much to go on and all that can be done is to repeat what has been written above. If all else fails, a repair service is available for a nominal, flat fee.

# Board track layout

This diagram shows the board tracks without the ground plane. Most floating pads are connected to the ground plane. The exception are the center pins on the IF transformer secondaries of T2, T3 and T4, along with Pins 1 and 8 of U3. Red lines are top side tracks and Blue lines are bottom side tracks.

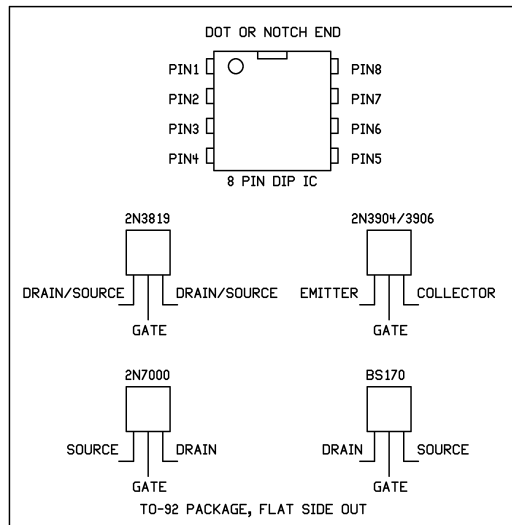
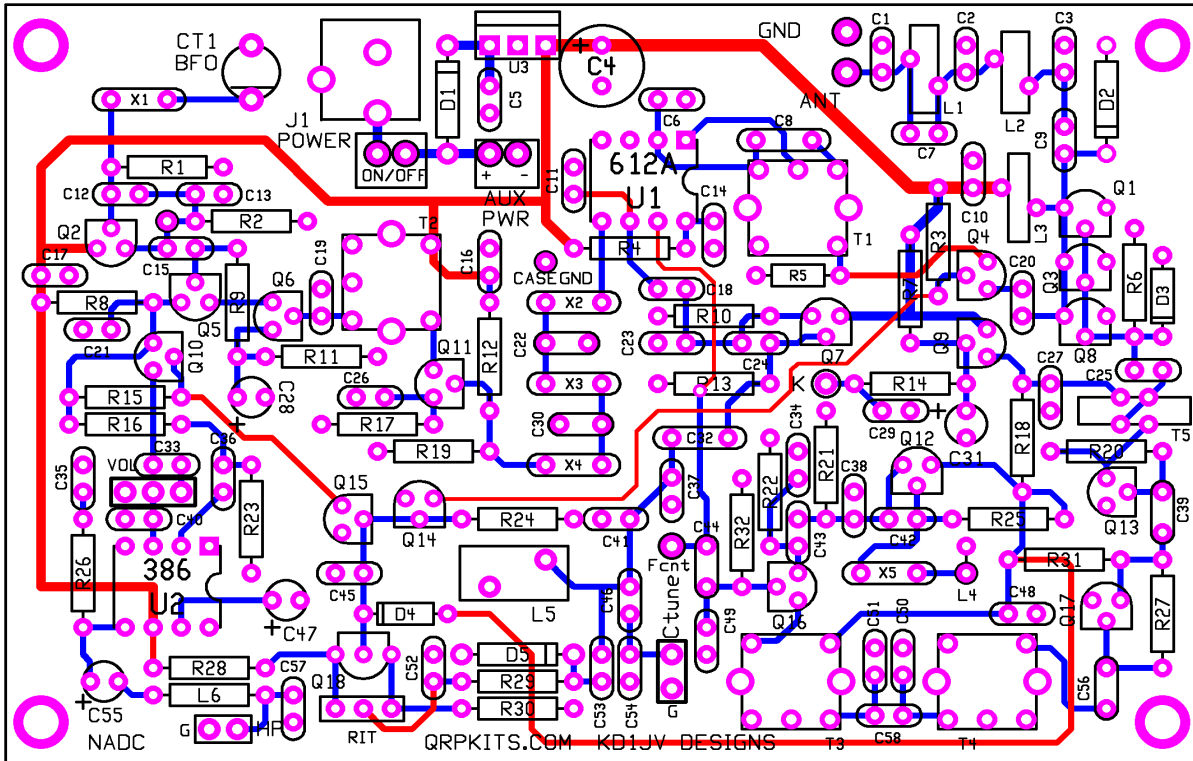

Schematic 40 meter version

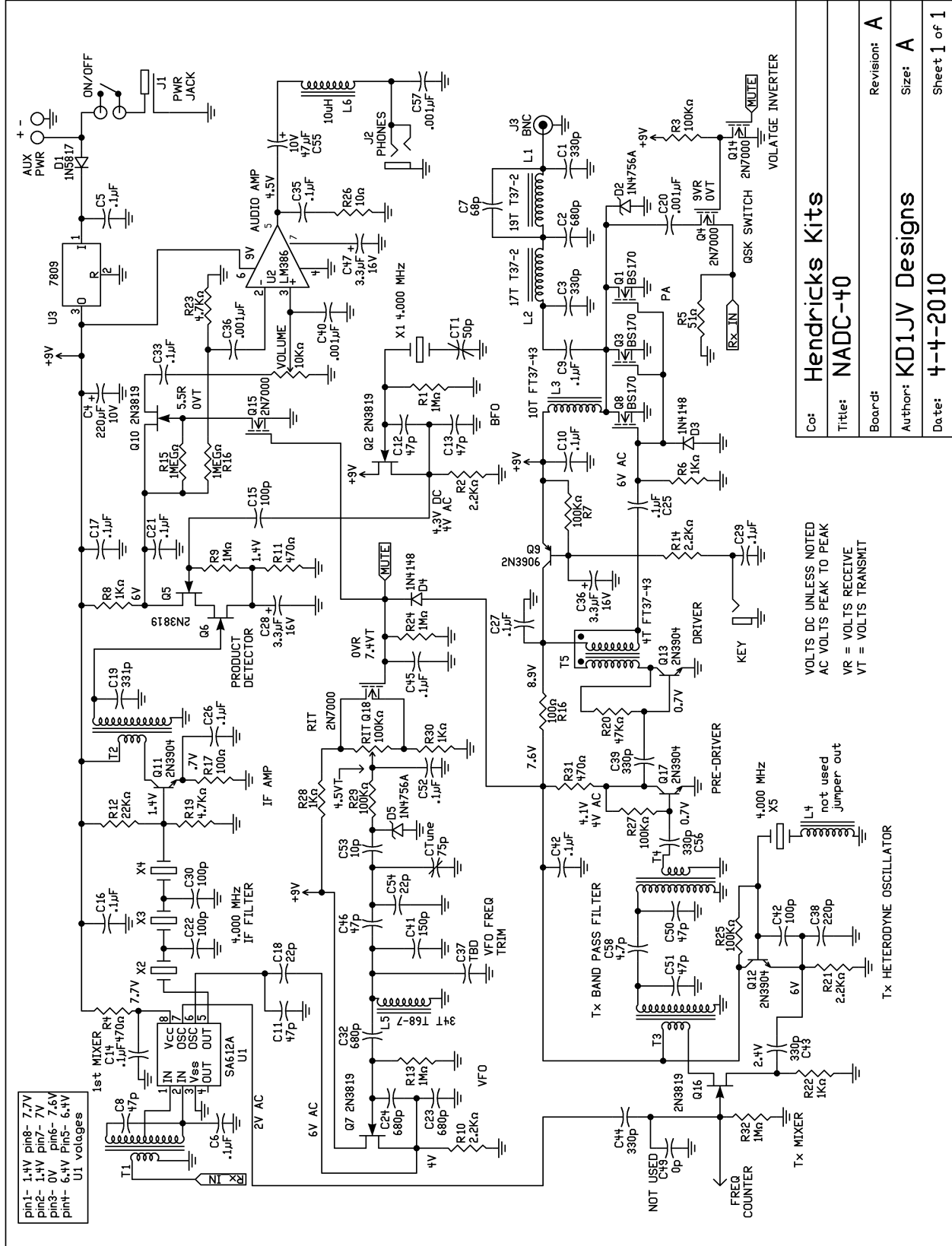

30 meter version :

