

Arizona ScQRPion QRP Club

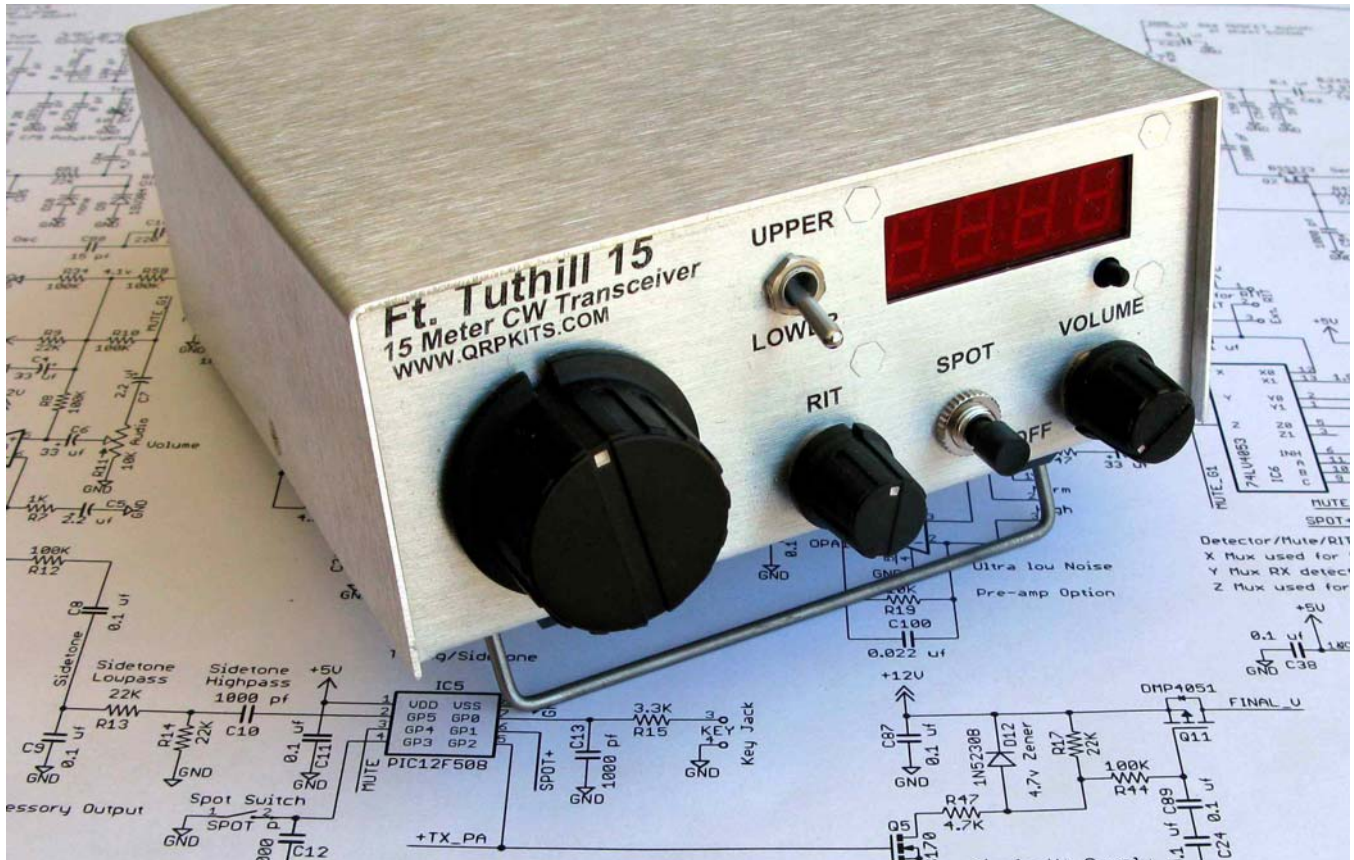

Ft Tuthill 15

5w DC CW Transceiver for 15m
Part 2 of 2, version 5

by Dan Tayloe, N7VE and Ken LoCasale, WA4MNT

Table of Contents

Building the Kit, continued.....	5
Installation of power sources (5 V, 11 V, 12 V).....	5
Power Source Tests.....	7
Installation of ICs – Part 1	9
IC Test 1.....	10
IC Test 2.....	11
Installation of ICs – Part 2	14
IC Test 3.....	15
IC Test 4.....	16
Installation of mixer band pass filter components	18
Mixer BPF Test 1.....	23
PCB modification.....	23
PCB Mod Test.....	24
VFO and TX installation.....	25
VFO/TX Test1	27
VFO/TX Test2	29
VFO/TX Test3	31
Transmitter LPF Tests.....	32
VFO alignment.....	32
Transmitter Tests	34
Placing the Kit into a Case.....	35
Chassis Preparation.....	36
Decal installation	36
Connecting Jacks, Button, and Controls to the Case	38
Final frequency tweaks	45
A few tips on using the transceiver.....	46
How “spot” and RIT works.....	46
How “spot” and XIT works	47
Using RIT to escape QRM.....	48
What RIT setting to use when calling “CQ”	49
“Key down” transmitter protection mode	49
“V2” sign on message.....	49
A note on headphone sensitivity	50
Rig problems: Dead TX plus Howling Receiver – The HSOD	51

List of Figures

Figure 1. Location of power source components plus one misc inductor	5
Figure 2. From right to left, identification of 2N3904, 1N4001, 78L05, and 4.7 uH choke	6
Figure 3. Board with 12 V, 11 V, and 5 V power sources installed	7
Figure 4. Location of misc ICs plus Y1, a 15 MHz crystal	9
Figure 5. Identification of NE5532, 12F508, 74LV4053 and Y1, a 15 MHz crystal. 8 pin socket optional	10
Figure 6. Temporary installation of the 10K RIT pot, SPOT switch, and Headphone jack	10
Figure 7. Varactor test point for voltage measurements	11
Figure 8. Board with installation of IC3, IC5, IC6, Y1 and misc test controls	13
Figure 9. Placement of IC1, IC3, BS170 MOSFETs and some 1 uH chokes.....	14
Figure 10. Parts identification for the 1 uH chokes, NE5532, CA3086, and six BS170 MOSFETs.....	14
Figure 11. R11 pads shorted for audio tests.....	15
Figure 12. Permanent jumpers put in place on J1 and J2.....	15
Figure 13. Board with ICs installed, BS170s, and 1 uH chokes installed	17
Figure 14. Placement of mixer bandpass filter components	18
Figure 15. Mixer filter parts needed. Three trim caps, two T37-6 cores, and red enamel wire.....	18
Figure 16. Orientation of the flat side of the three trim caps are important!	19
Figure 17. Preset the two trim caps with the “arrow” positions as shown.....	19
Figure 18. First turn of L1. Short end of the wire is out the bottom side.	20
Figure 19. L1 after the first few turns. Windings are being added clockwise from the start.....	20
Figure 20. L1 with all 18 turns in place	21
Figure 21. Hold both the short starting end of the red and green wires.....	21
Figure 22. Four turns of green wire added clockwise from the red wire starting position.....	21
Figure 23. Red and green wire aligned for installation, leads trimmed and stripped to the core edge....	22
Figure 24. Red wire and green wire pair holes identified, L1 shown installed vertically.	22
Figure 25. Winding of L8. Turns are added counter-clockwise around the core.	23
Figure 26. L1, L8, plus the three trim caps shown installed on the board.....	23
Figure 27. Cut and jumper modification. L1 trace cut, jumper added.....	24
Figure 28. Installation of VFO, transmitter and T1 components.....	25
Figure 29. L4, 9T of #28 red enamel wire wound counterclockwise and trimmed as shown	26
Figure 30. Wire preparation for the wire used in T1	26
Figure 31. Preparation of T1 and picture of the PCB holes for T1	26
Figure 32. T1 shown mounted vertically.	27
Figure 33. L9 VFO coil. 21 turns, add a tap, then wind 7 more turns to finish.....	28
Figure 34. L9 VFO coil leads trimmed and formed.....	28
Figure 35. L9 mounted. Pads labeled 1, 2, and 3 are used as shown. Pad 3 is used for the tap.	29
Figure 36. Wire loop installed at TP1, test point 1	29
Figure 37. Installation of IC7, a 74AHC04.....	30
Figure 38. L6, L4 and L5 all mount vertically.....	30
Figure 39. Finished PCB board.....	31
Figure 40. View of VFO area including trim cap C82 and L9	32
Figure 41. Suggested frequency counter pick off point for the receiver LO.	33
Figure 42. Front panel view with decals applied and optional Digital Dial frequency counter	35
Figure 43. Rear panel view with decals applied	35

Figure 44. Drawing of the front panel before controls are mounted 36

Figure 45. Picture of decal locations on the front and back panels 37

Figure 46. Visualization of Antenna, TX tuning pot, spot switch, and headphone connections..... 38

Figure 47. Visualization of 12 V power jack, volume control and Digital Dial connections..... 39

Figure 48. Optional digital dial and additional 12 V filtering, 100 ohm and 100 uF cap..... 39

Figure 49. Volume Control tabs bent to provide clearance for optional Digital Dial 40

Figure 50. Trimmed red plastic bezel and shown mounted in place 41

Figure 51. Visualization of TX key jack..... 41

Figure 52. Mounting hardware for the main tune capacitor 42

Figure 53. Connection of main tune capacitor and Hi/Low band Switch..... 42

Figure 54. Option to set Hi range to cover 21.045 to 21.000 MHz. Use a single series 15 pF cap..... 43

Figure 55. RIT, Spot, Hi/Low Band Switch and optional Digital Dial RF connections (right side)..... 44

Figure 56. Power jack connections, headphone and key jack connections. 44

Figure 57. Board in case. All front to back wires routed along the CA3086 edge of the board..... 45

Building the Kit, continued

Installation of power sources (5 V, 11 V, 12 V)

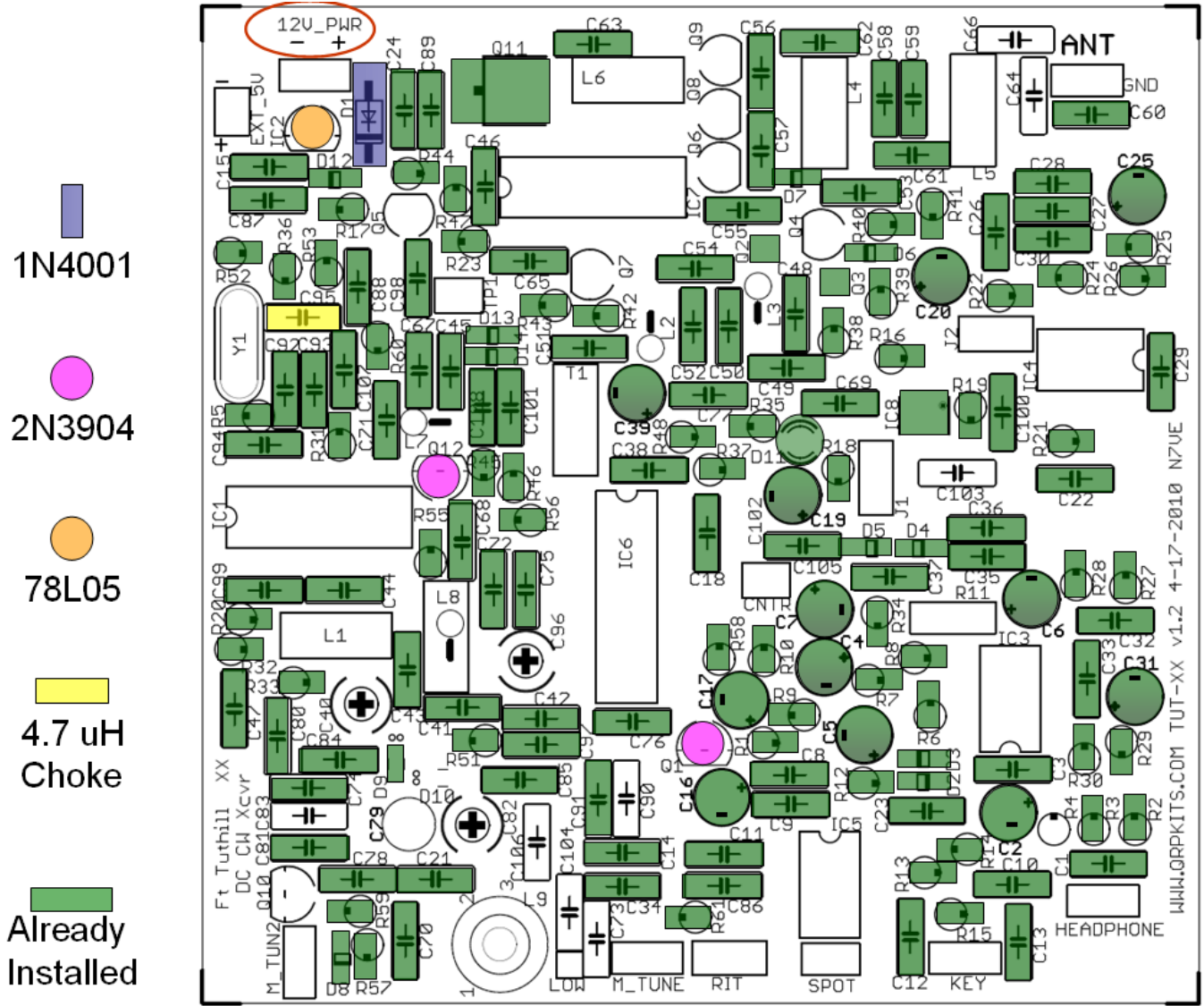

Figure 1. Location of power source components plus one misc inductor

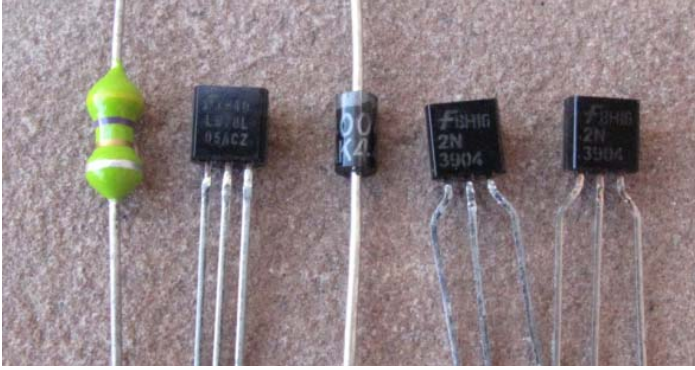

Figure 2. From right to left, identification of 2N3904, 1N4001, 78L05, and 4.7 uH choke

Install the large black 1N4001 diode. □ D1 – Save leads for temporary power connection below

Install the 2N3904 transistors □ Q1, □ Q12

Install the 78L05 □ IC2

Install the 4.7 uH inductor (Yellow-Violet-Gold) □ C95 *The inductor is mounted on end like a resistor with the bare leg facing Y1, the crystal. See the installed component picture on the next page.* This component is normally a capacitor (hence “C95”), but an inductor was needed to move a large spur at 21.000 MHz down a few KHz, below the 15m band.

Attach temporary power leads to the 12V_PWR terminal circled in red in the above diagram. The excess leads from the 1N4001 diode are thicker than normal and work well here.

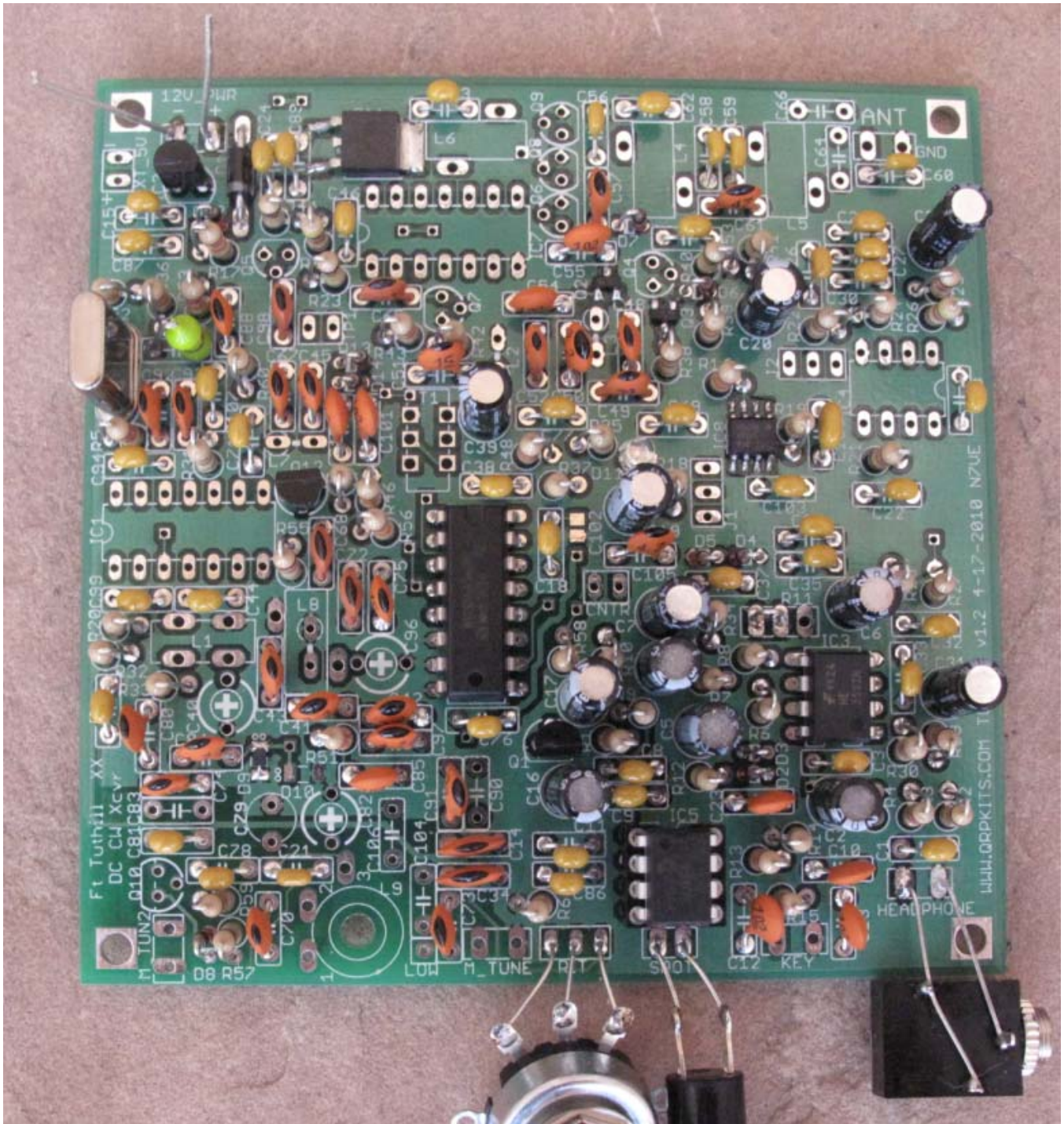

Figure 3. Board with 12 V, 11 V, and 5 V power sources installed

This picture has parts from the next section as well. I seemed to have missed taking a picture of this step!

Power Source Tests

Connect a 12v power source. The following are a group of tests to be done:

- The LED on the board (D11) should light up blue.
- The current draw when connected to 12v battery will be in the **6.9** mA range (roughly).

The following are a series of DC checks on the pins of IC1, which is not installed yet. Use the bottom right mounting hole as a ground. All mounting holes are grounded except for the bottom left hole in the VFO area near Q10.

- pin 1: 10.5v This verifies that the RX supply voltage filter section is working.
- pin 2: 5.0v
- pin 3: 0v (near zero)
- pin 4: 5.0v
- pin 5: 0v (near zero)
- pin 6: 2.5v
- pin 7: 0v (near zero)
- pin 8: 5.0v
- pin 9: 2.5v
- pin 10: 0v (near zero)
- pin 11:
- pin 12: 2.5v
- pin 13: 0v (near zero)
- pin 14: 5v

Disconnect the 12v power source.

Installation of ICs – Part 1

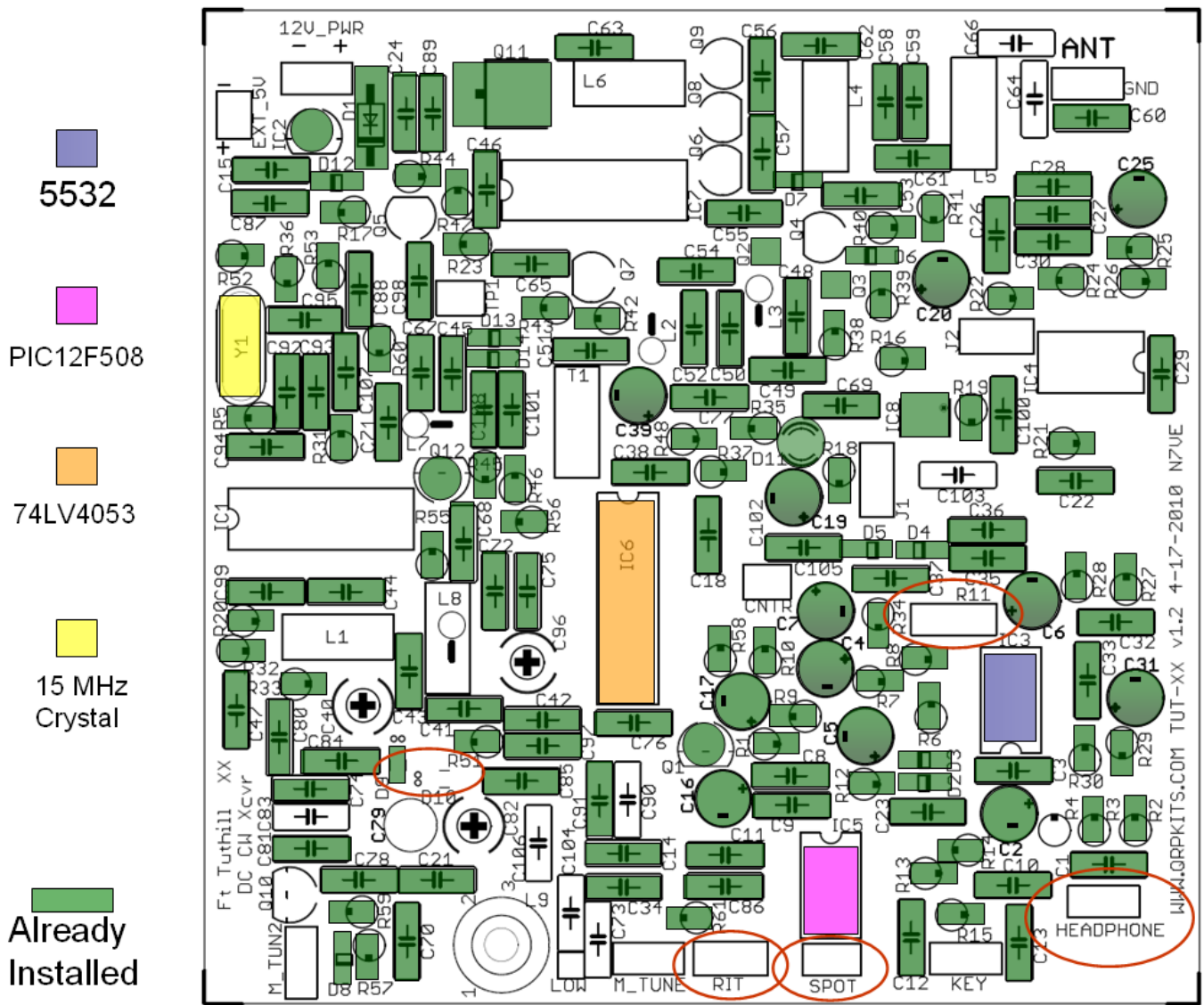

Figure 4. Location of misc ICs plus Y1, a 15 MHz crystal

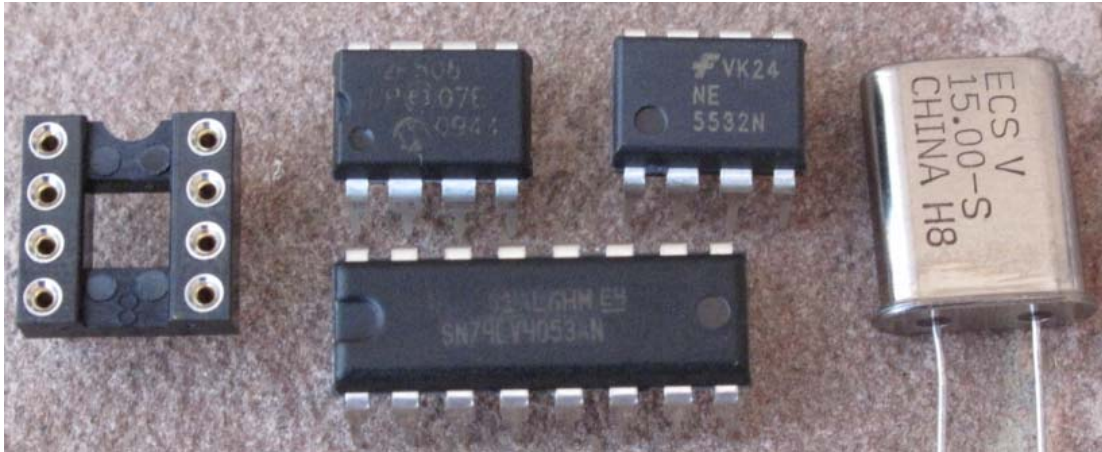

Figure 5. Identification of NE5532, 12F508, 74LV4053 and Y1, a 15 MHz crystal. 8 pin socket optional

Install one of the two NE5532 op-amps IC3. ***Make sure the notch on the IC lines up with the notch on the board! Do not install backwards!*** Note that the “notch” end of the IC is the end with the ***small circular “dot”*** as seen in the picture above.

Install the timing processor, PIC12F508 IC5. ***Make sure the notch on the IC lines up with the notch on the board! Do not install backwards!*** From the picture above this IC has both a “notch” and a “dot” on the notch end of the IC. It is optional to use an 8 pin socket for this IC which is useful for potential software upgrades.



Figure 6. Temporary installation of the 10K RIT pot, SPOT switch, and Headphone jack

Temporarily add the headphone jack to the headphone output located in the bottom right corner of the board. Keep this temporary connection for the rest of the kit build.

IC Test 1

Connect a 12v power source and conduct the following tests:

The current draw when connected to 12v battery will be in the **13.2 to 12.7 mA** range.

The following are a series of DC checks on the pins of IC3:

- pin 8: 11.5v
- pin 7: 4.1v

Attach headphones to the headphone jack and touch the middle hole of R11 (three pads for the volume control), located just above and to the left of IC3. A loud “hum” ought to be heard

Disconnect the 12v power source.

Connect a 12v power source and conduct the following tests:

The current draw when connected to 12v battery will start in the **13.2 mA** range until the “V2” sign on is sent in cw, then the current will drop to the **12.7 mA** range, same as in the previous test.

Listen in the headphones for the side tone as the timing processor IC5 sends “V2” in CW about 3 seconds after the board is powered up

Disconnect the 12v power source.

Install the Mute/Detector/RIT analog gate 74LV4053 IC6. ***Make sure the notch on the IC lines up with the notch on the board! Do not install backwards!***

Temporarily install the RIT 10K panel mounted pot as shown above RIT
Temporarily install the spot switch as shown above SPOT

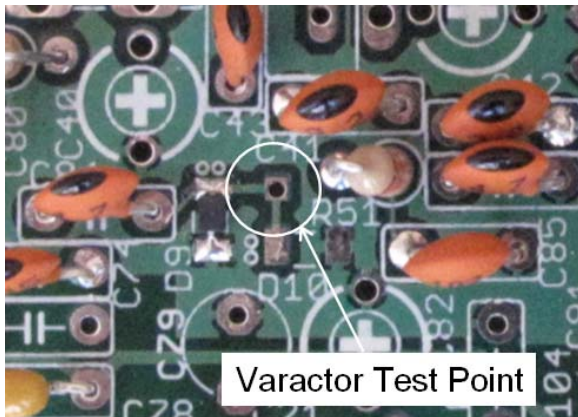

Figure 7. Varactor test point for voltage measurements

IC Test 2

Connect a 12v power source and conduct the following tests:

- The current draw when connected to 12v battery will start in the **13.7** mA range until the “V2” sign on is sent in cw, then the current will drop to the **13.3** mA range, same as in the previous test.
 - Check RIT voltage across RIT diode D9 at the test point shown above. Changing RIT pot will change diode voltage ranging from 1.2v with RIT pot all the way one direction to 5v with the RIT pot turned all the way the other direction.
 - Press the “SPOT” button and hear a "tick" once a second.
 - Measure the RIT diode voltage to be **2.8v** and make sure the RIT tuning pot has no effect on this voltage measurement. This is the TX tuning voltage which is fixed.
 - Press the “SPOT” button again, an "R" will be sent, and the diode voltage will be the variable RIT pot voltage once again.
- Keep the RIT pot installed! It must be in place to have the VFO operate properly!***
- Take a lead scrap and jumper across the “KEY” jack, the keying side tone can be heard in the headphones. Don’t worry, nothing on the TX side is built yet. When keyed for more than 3 seconds, the transmitter side tone can be heard going into “dotting” mode to protect the finals.
- Disconnect the 12v power source.***



Figure 8. Board with installation of IC3, IC5, IC6, Y1 and misc test controls

Installation of ICs – Part 2

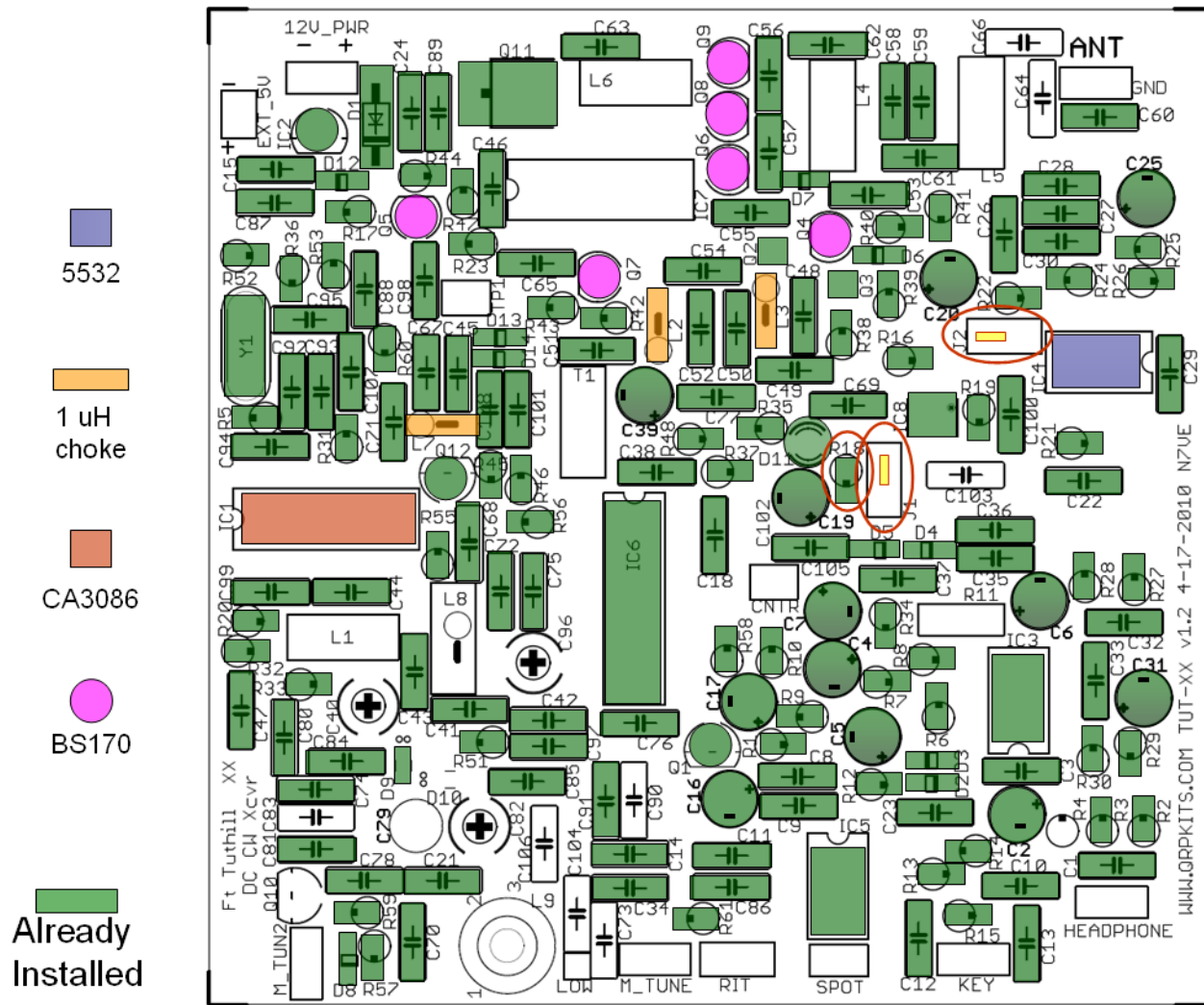

Figure 9. Placement of IC1, IC3, BS170 MOSFETs and some 1 uH chokes

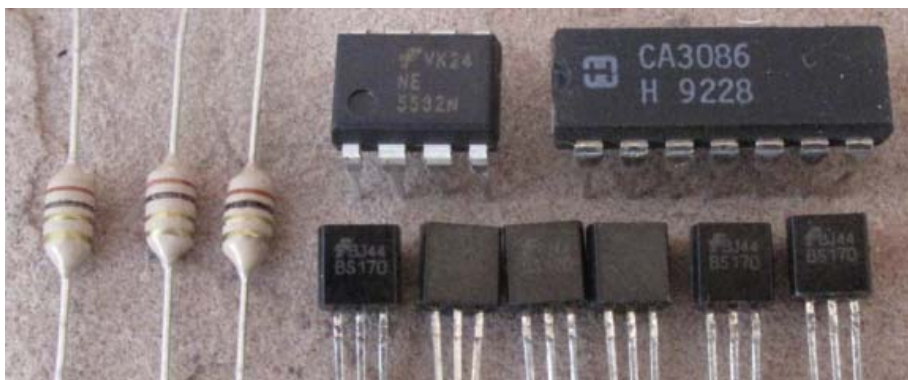

Figure 10. Parts identification for the 1 uH chokes, NE5532, CA3086, and six BS170 MOSFETs

Install the op-amp, NE5532 IC4. ***Make sure the notch on the IC lines up with the notch on the board! Do not install backwards!*** Note that the “notch” end of the IC is the end with the *small circular “dot”* as seen in the picture above.

Temporarily short the R11 pads (center and left). See the picture below. Keep this in place until the volume control pot is installed.

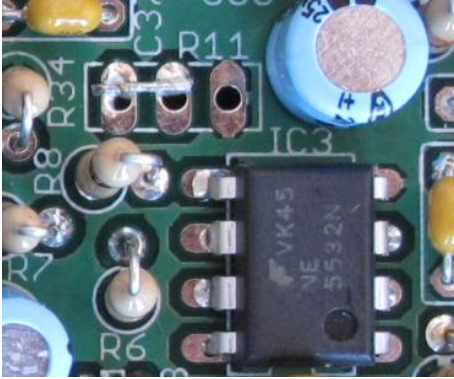

Figure 11. R11 pads shorted for audio tests

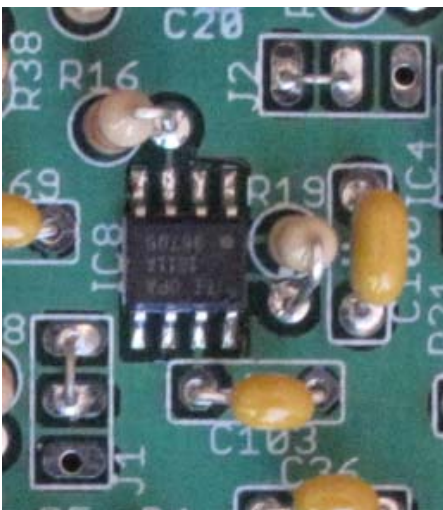

Figure 12. Permanent jumpers put in place on J1 and J2

Install jumpers as shown above on J1 and J2. These jumpers select the low noise OPA1611 as the first op-amp preamp stage.

IC Test 3

- Connect a 12v power source and conduct the following tests:
- The current draw when connected to 12v battery will be in the **19.1** mA range.
- Tapping yellow 0.1 caps C18, to the right of the 74LV4053 chip with a small screw driver should produce some noticeable microphonic clicks.
- Touching R18 just left of J1 should produce a loud hum

DC voltage checks on IC4:

pin 1: 5v pin 7: 5v pin 8: 10.5v

Disconnect the 12v power source.

Install the six BS170 MOSFET transistors, Q5, Q7, Q4, Q6, Q8, Q9 ***Keep the leads short, with transistor bodies close to the pc board.***

Install the three 1 uH inductors on end like resistors. L7, L3, L2 ***Mount L2 “backwards” from the PCB layout, with the vertical leg pointed towards C39.***

Install the transistor array, CA3086 IC1. ***Make sure the notch on the IC lines up with the notch on the board! Do not install backwards!***

IC Test 4

Connect a 12v power source and conduct the following tests:

The current draw when connected to 12v battery will be in the **28** mA range.

DC voltage checks on IC1:

<input type="checkbox"/> pin 1: 10.3v	<input type="checkbox"/> pin 2: 3.4v	<input type="checkbox"/> pin 3: 2.8v	<input type="checkbox"/> pin 4: 3.2v
<input type="checkbox"/> pin 5: 2.5v	<input type="checkbox"/> pin 6: 2.2v	<input type="checkbox"/> pin 7: 1.5v	<input type="checkbox"/> pin 8: 5v
<input type="checkbox"/> pin 9: 1.8v	<input type="checkbox"/> pin 10: 1.7v	<input type="checkbox"/> pin 11: 2.8v	<input type="checkbox"/> pin 12: 2.2v
<input type="checkbox"/> pin 13: 2.3v	<input type="checkbox"/> pin 14: 5v		

These DC readings may be a bit off since the 15 MHz crystal oscillator is now running which may affect the DC readings of a few of these pins.

Disconnect the 12v power source.

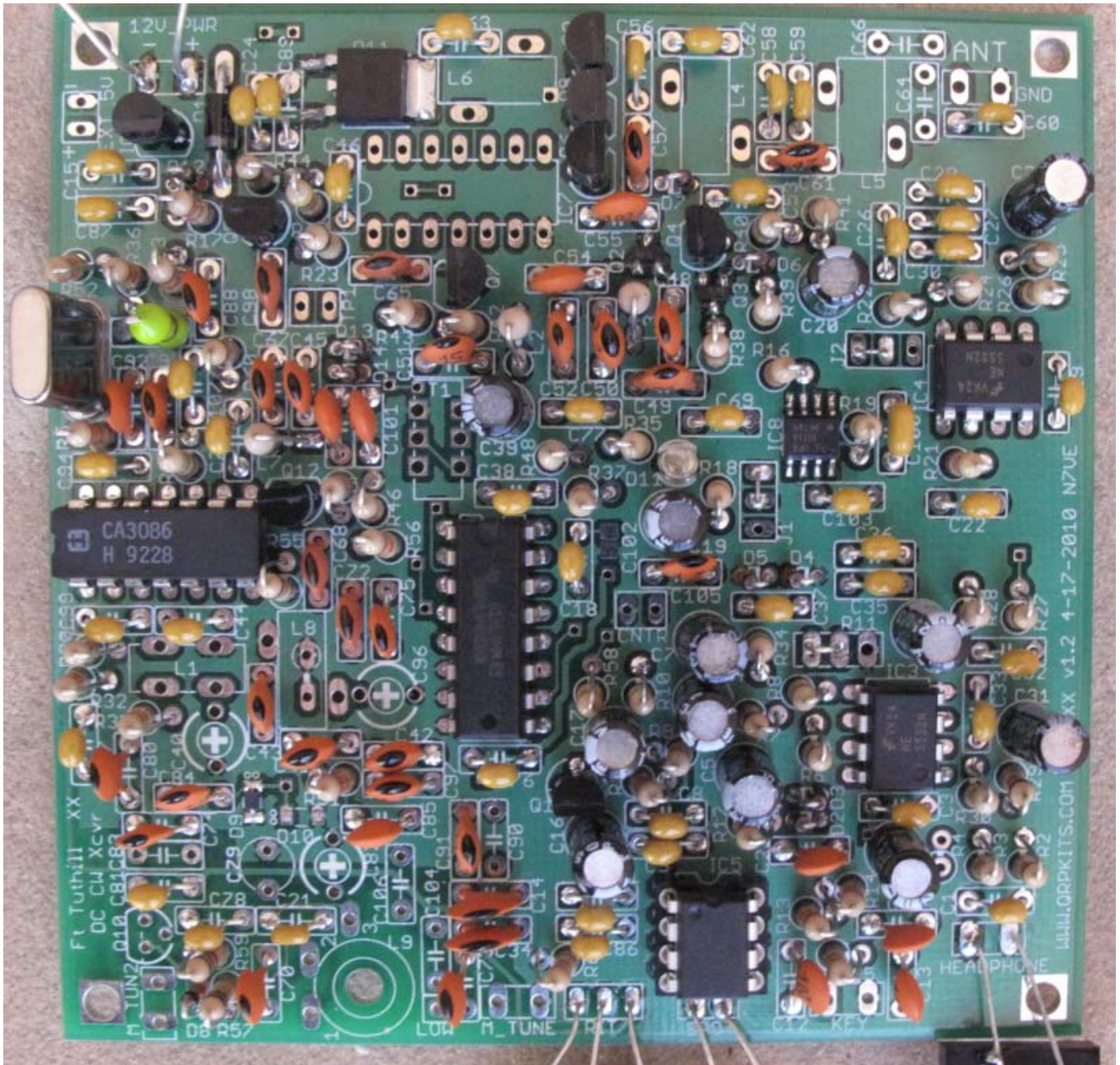

Figure 13. Board with ICs installed, BS170s, and 1 uH chokes installed

Installation of mixer band pass filter components

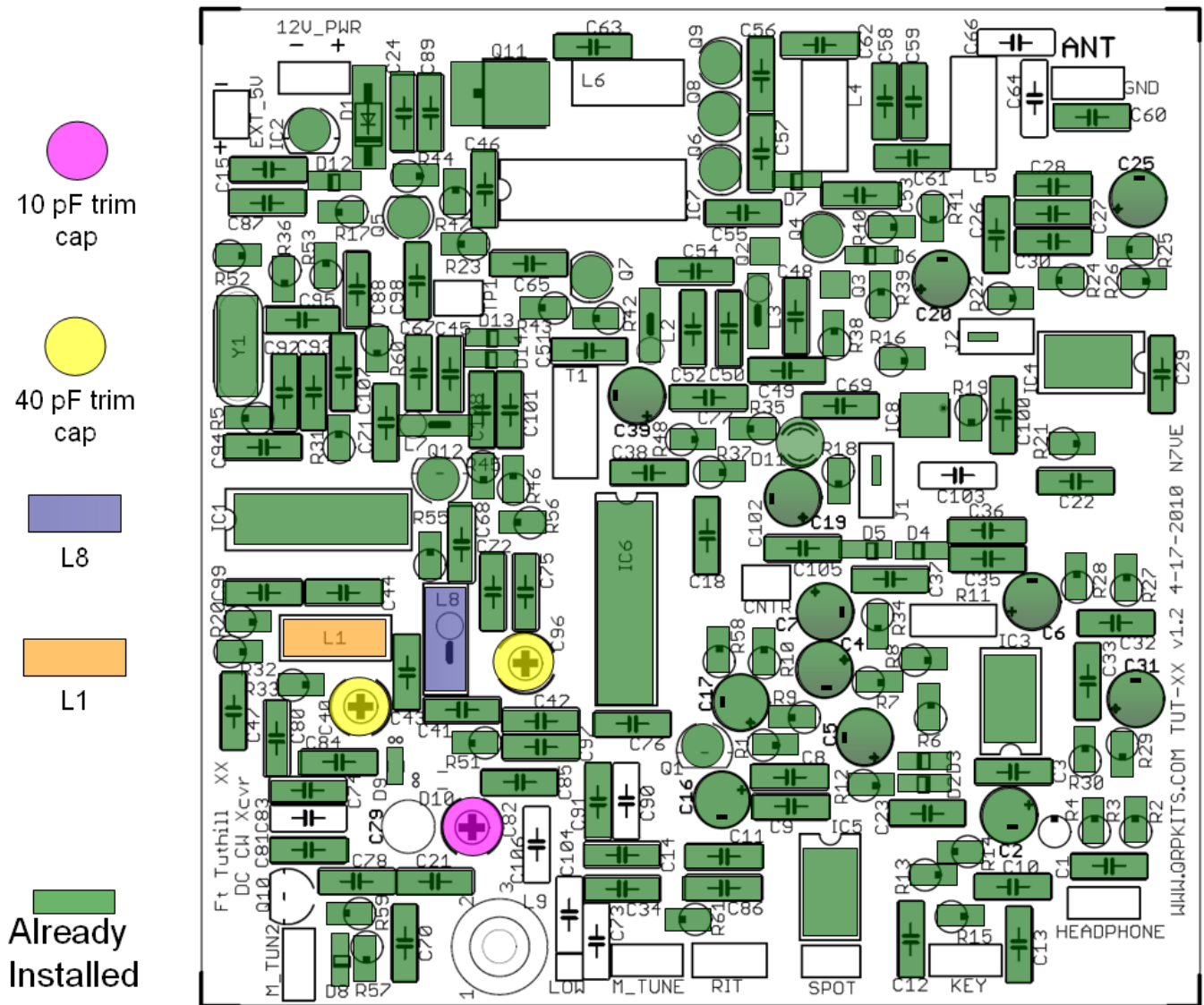

Figure 14. Placement of mixer bandpass filter components



Figure 15. Mixer filter parts needed. Three trim caps, two T37-6 cores, and red enamel wire

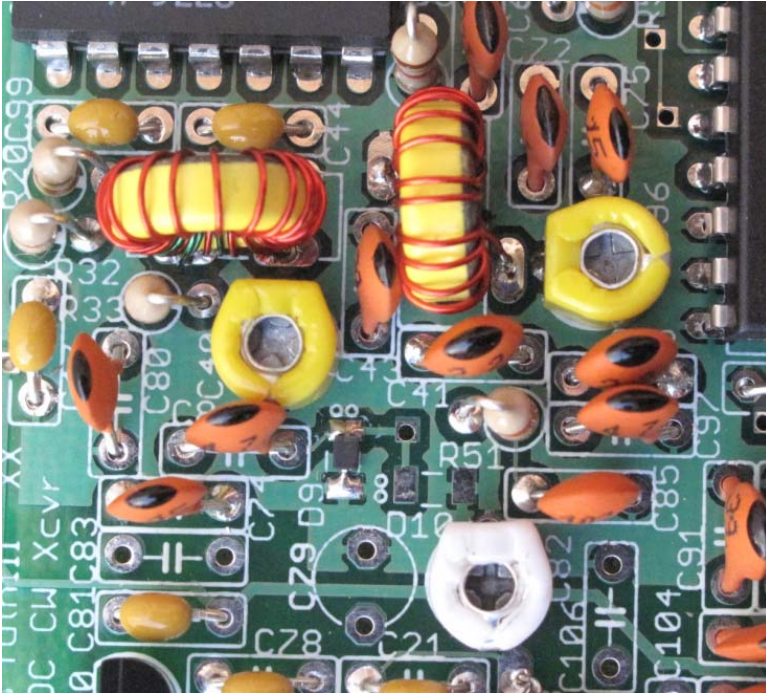

Figure 16. Orientation of the flat side of the three trim caps are important!

Install the white trim cap *with the flat edge oriented as shown above* □ C82. Actually this is a VFO trim cap, but this is a good time to install it.

Install the two yellow trim caps *with the flat edge oriented as shown above* □ C40, □ C96. Notice that the internal trimmer adjustment surface forms the pointer of an arrow. Preset these two yellow trimmers to the “arrow” positions shown in the picture below

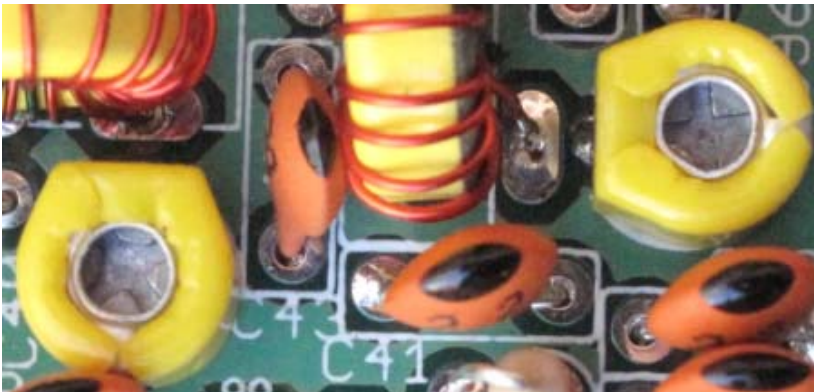

Figure 17. Preset the two trim caps with the “arrow” positions as shown

These trimmer capacitors can be hard to adjust without the right size screw drive blade. The secret is to get a set of straight blade screw driver bits (you don't need an entire screw driver) and find one that just fits the width of the top of the trimmer cap. Adjustment is easy with a screw driver blade that fits right!

All the coils in this kit need to be wound a certain direction in order to properly line up with the holes in the board. As it turns out, there are *two different ways* toroid cores can be wound, and we want to make sure they are wound the right way or they might or *might not match up*.

All the toroid cores in this kit are *wound in the same direction except for this first one*. It is wound backwards compared to all the rest, so it will be wound first to get it out of the way.

Cut 10" of red wire and 4" of green enamel wire. Take one yellow and place the red wire through it as shown below:

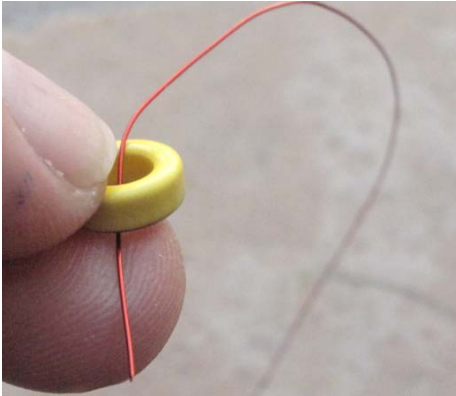

Figure 18. First turn of L1. Short end of the wire is out the bottom side.

Each pass of the wire through the center of the core is one turn. Thus the picture above shows one turn of L1. The short end sticks out the bottom. This coil needs 18 turns or 18 passes total through the center of the core. L1 needs to be wound with the windings added *clockwise* around the core from the starting point shown above. See the picture below. Each turn is added threading the wire in from the bottom side.

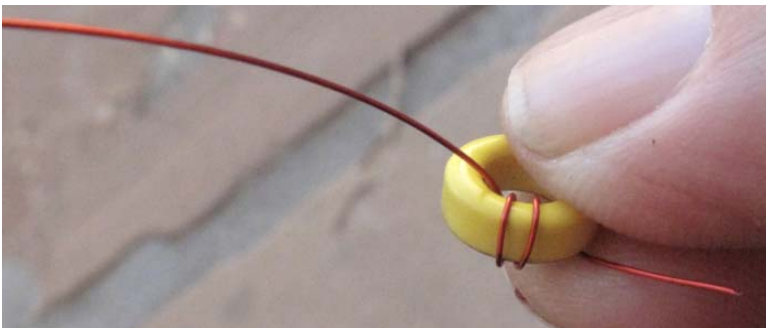

Figure 19. L1 after the first few turns. Windings are being added clockwise from the start.

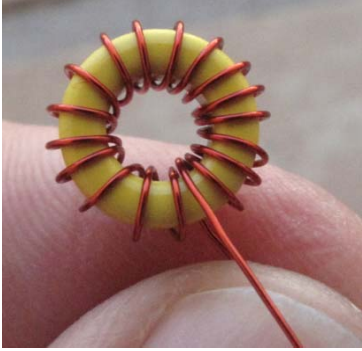

Figure 20. L1 with all 18 turns in place

The picture above shows L1 with all 18 turns. The turns should be adjusted so that they are uniformly spaced over the entire circumference of the core.

L1 has two windings, so the next step is to add the 4" green wire as the second winding as shown below:

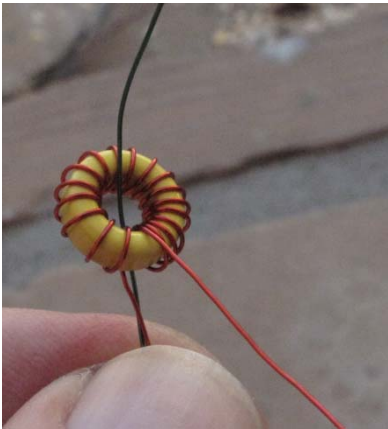

Figure 21. Hold both the short starting end of the red and green wires

The short starting end of the green wire is held with the short starting end of the red wire. With the green wire through the center of the core, this is the first turn of the green wire. Three more turns of the green wire are added, *clockwise*, wrapped in between the first four windings of the red wire. This is shown below:

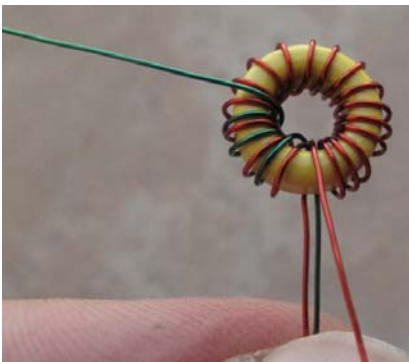

Figure 22. Four turns of green wire added clockwise from the red wire starting position

After the four turns of green wire are added, the two green wire pairs need to be line up across from each other and the two red wire pairs also need to be line up across from each other in preparation for installation as shown below.

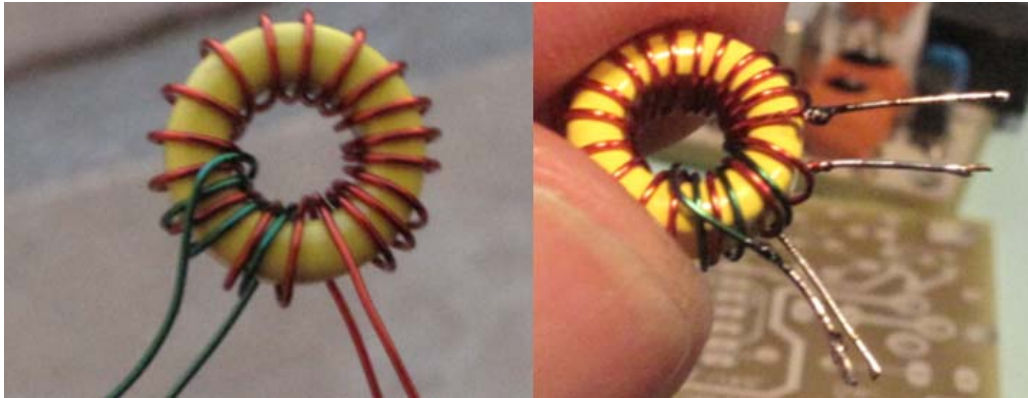

Figure 23. Red and green wire aligned for installation, leads trimmed and stripped to the core edge

The wire used in this kit uses low temperature insulation that burns easily. Do not use a match! I strip the leads by placing a “blob” of solder on the end of the solder tip, then place the end of the wire in the blob to strip it. Work from the end of the wire up to the edge of the core. As the insulation burns off, it leaves black residue, so you may have to wipe of the old solder and add a fresh solder blob several times before you are finished with a given lead.

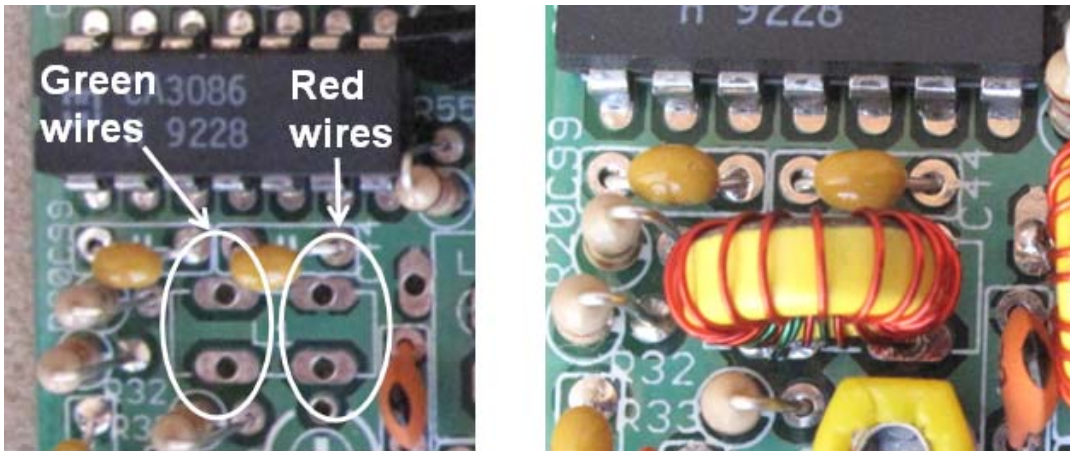

Figure 24. Red wire and green wire pair holes identified, L1 shown installed vertically.

Install L1 as shown above □ L1

Take another T37-6 core and 10” of red enamel wire and wind it with 18 turns *Counter-clockwise* from the starting point as shown below. Remember each pass through the center is one turn, so the first picture below counts as one turn. Winding the turns as shown is necessary to the leads to line up with the PCB layout.

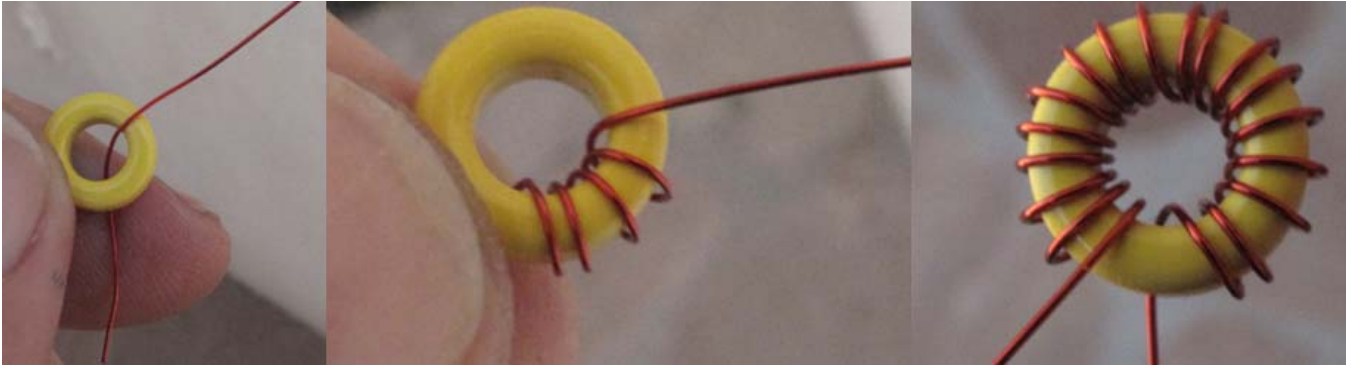

Figure 25. Winding of L8. Turns are added counter-clockwise around the core.

Trim the leads to perhaps 1/2" in length, strip the leads so that they are solder tinned up to the edge of the core. L8 is now ready for installation.

Install L8 vertically as shown below L8

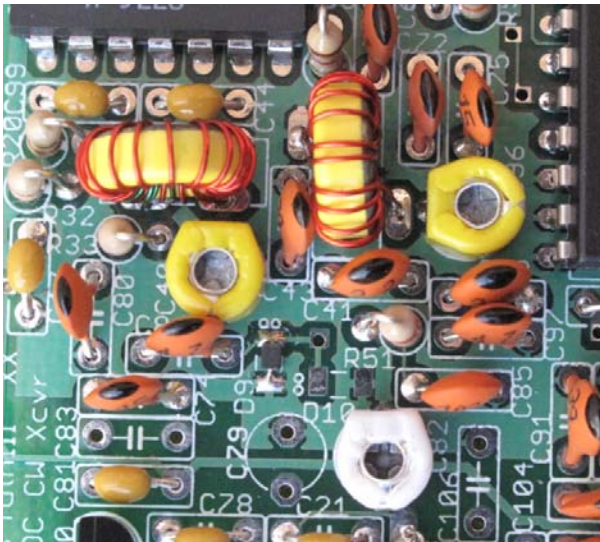

Figure 26. L1, L8, plus the three trim caps shown installed on the board

Mixer BPF Test 1

- Connect a 12v power source and conduct the following tests:
- The current draw when connected to 12v battery will be in the **29** mA range.
- Disconnect the 12v power source.***

PCB modification

A cut and jumper is needed on the current PCB. This cuts a trace connected to a pad on L1 installed above and installs a jumper between pin 1 and pin 14 of the CA3086 (IC1). This is shown below.

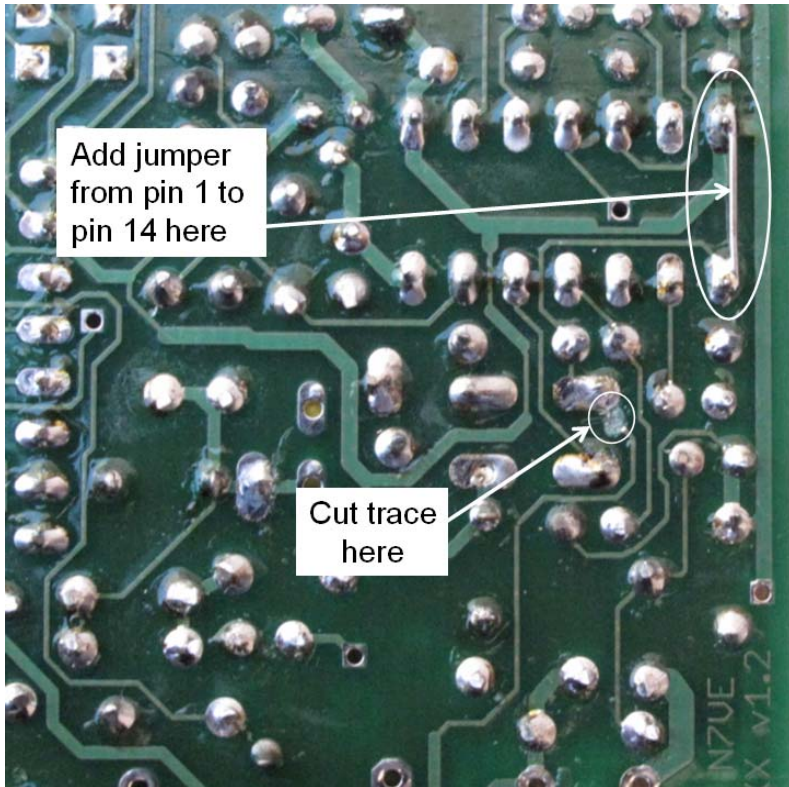

Figure 27. Cut and jumper modification. L1 trace cut, jumper added.

The PCB trace is very thin and is easy to scratch through with a knife, small screw drive blade, or other sharp, pointed object like a wood screw or a small nail. ***Make very sure the trace is fully cut!*** We do not want the 11v line to be shorted to 5v!

This old trace came from the 11v supply output which can cause “whoop” on the transmit signal as this voltage slowly sags (due to the R1/C17 R/C time constant of the Q1 11v receiver supply voltage filter) as the voltage drop across the input diode to the board changes between transmitting (0.75 amp current draw) and not transmitting (0.039 amp current draw). The jumper (a lead scrap) connects pin 1 and L1 instead to 5v (pin 14), a well regulated voltage source. The mixer performance appears unchanged using the lower, better regulated supply voltage.

With this change, everything in the TX chain, outside of the finals themselves, runs off of 5v and will not be affected by lower battery voltage. The minimum supply voltage for the kit is set by the voltage requirements of the op-amps in the receiver and their common mode operating range and supply voltage limitations.

PCB Mod Test

- Connect a 12v power source and conduct the following tests:
- The current draw when connected to 12v battery will be in the **29** mA range (same as before the modification).
- Disconnect the 12v power source.***

VFO and TX installation

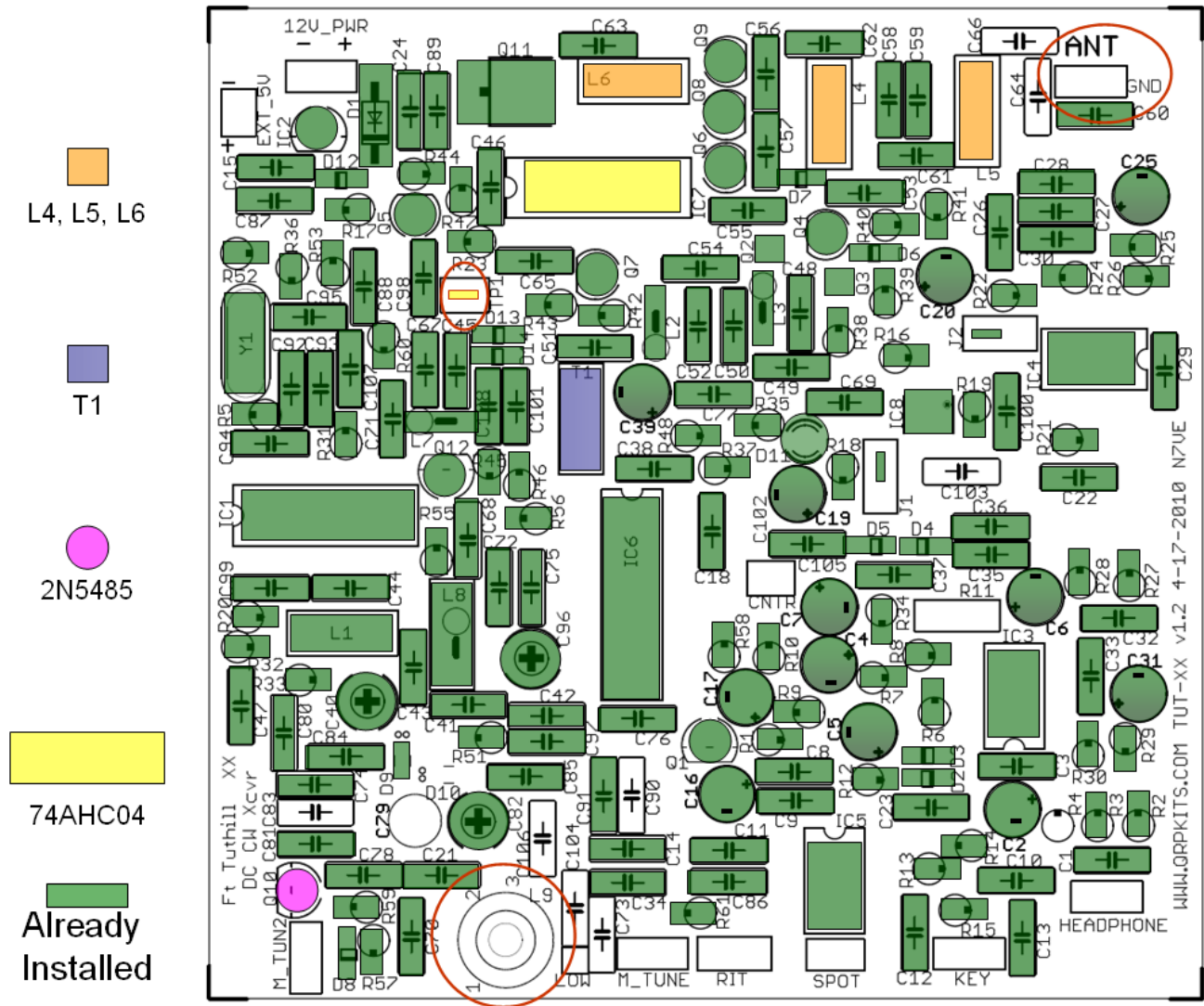

Figure 28. Installation of VFO, transmitter and T1 components

L4 preparation: Take another T37-6 core and 6" of red enamel wire and wind it with 9 turns *counter-clockwise* from the starting point as shown below. Remember each pass through the center is one turn, so the first picture below counts as one turn. Winding the turns as shown is necessary to the leads to line up with the PCB layout.

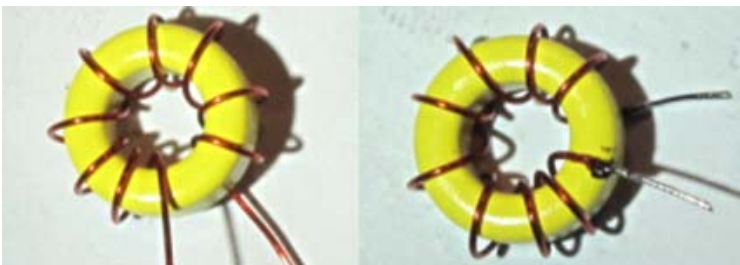

Figure 29. L4, 9T of #28 red enamel wire wound counterclockwise and trimmed as shown

- Install L4

L5 preparation: Take another T37-6 core and 6" of red enamel wire and wind it with 10 turns *counterclockwise* from the starting point as was done for L4 above. Winding the turns as shown is necessary to the leads to line up with the PCB layout.

- Install L5

T1 preparation

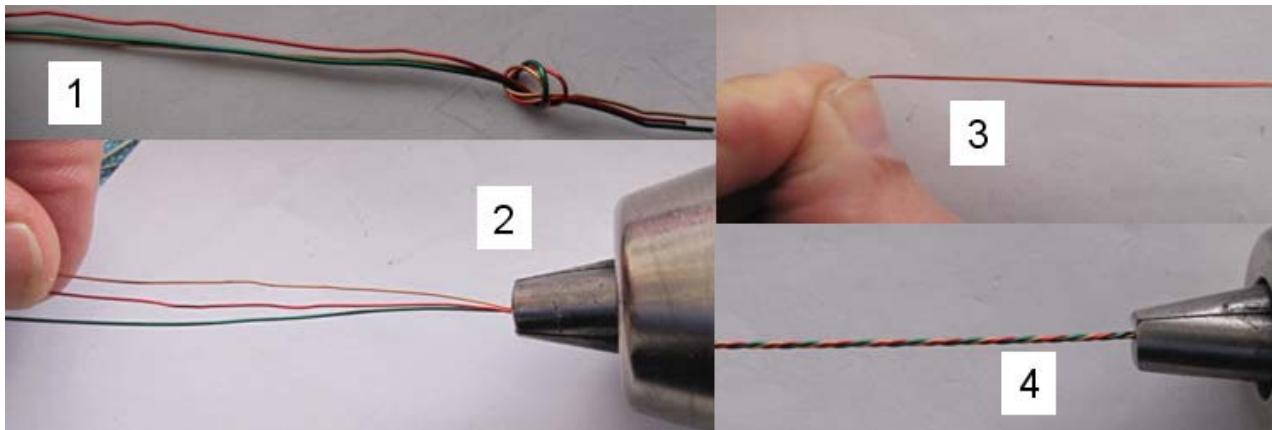

Figure 30. Wire preparation for the wire used in T1

- Take 18" of each of the three large #28 gauge wire, Red, Green, and Gold.
- Place the three wires together and knot the end as shown in 1) above.
- Place the knot in a drill chuck and tighten the drill chuck on the knot as shown in 2) above.
- Hold the far end of the wire taut as shown in 3) above
- Use the drill to twist the wire as shown in 4) above. The number of twists per inch is not very important.

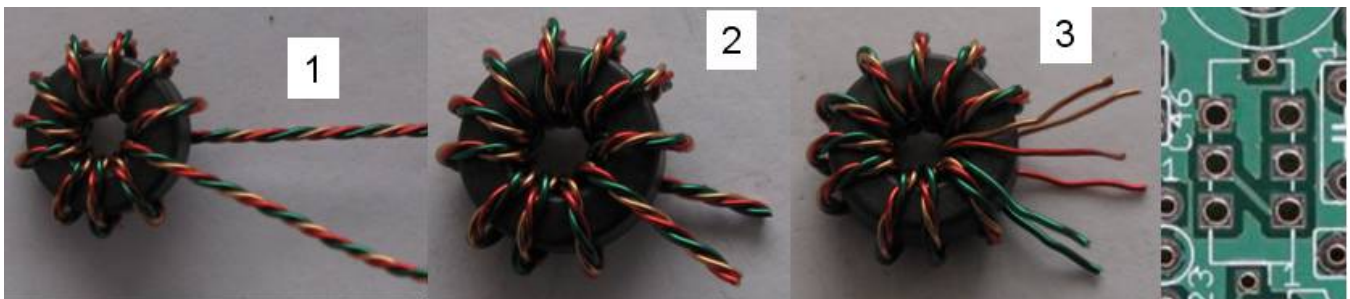

Figure 31. Preparation of T1 and picture of the PCB holes for T1

- Take the twisted wire prepared above and wrap 5 turns on a FT37-43 core as shown in 1) above. The FT37-43 is the only core that is not colored yellow.
- Trim of the excess wire allowing room for soldering the leads as shown in 2) above
- Untwist the wire and arrange them in color pairs as shown in 3) above. Pair the like colors as shown.
- Tin all six wires up to the bottom edge of the FT37-43 core. Keep the color pairs together as shown in 3 above!

The holes in the board for T1 have six holes arranged as three sets of two as shown below the top two holes are for one color pair (both red wires for example), the middle two holes are for the second color pair (both green for example), while the bottom two holes are for the third color pair (both gold wires for example).

- Install T1. Mount the core in the board vertically as shown below with the wire pairs lined up top, middle, and bottom. The color order is not important as long as the same colors are kept together in pairs.

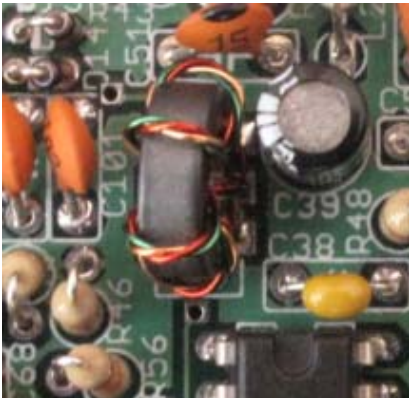

Figure 32. T1 shown mounted vertically.

VFO/TX Test1

- Connect a 12v power source and conduct the following tests:
- The current draw when connected to 12v battery will be in the **29** mA range.
- Disconnect the 12v power source.***

Preparation of VFO coil L9

L4 preparation: Take another T37-6 core and 15” of red enamel wire and start with 21 turns ***Counter-clockwise*** from the starting point as shown below. All the turns need to be wound ***side by side*** with no space between turns in order to fit on the core. ***Each turn needs to be wrapped snug to the core for***

best VFO stability. The # 28 gauge enamel wire easily molds itself to the surface of the core without too tension applied. **Do not pull too hard or you may break the wire!**



Figure 33. L9 VFO coil. 21 turns, add a tap, then wind 7 more turns to finish

In the above picture, 21 turns are added clockwise, a twist is added for a tap point, and then 7 more turns are added. The twist loop is then cut next to the twist point, and all three resulting leads are stripped and tinned. Every turn is added from the bottom. **After the tap “loop”, make sure the last 7 turns are added from the bottom as before, otherwise the VFO will not start.** In other words, all turns have to be wound in the same direction, each turn added from the bottom side, each turn added counter clockwise from the last turn.

□ When done, use an ohm meter across the start and the end leads to make sure the two wires at the tap point are soldered together.

The prepared leads are shown below. Notice that the end lead furthest from the tap point is laid out flat. This allows this one lead to be **soldered to the top side of the PCB only** in order to allow a turn to be removed if needed. Also note that the twist point of the tap as also been tinned in order to connect both halves of the coil at this point.

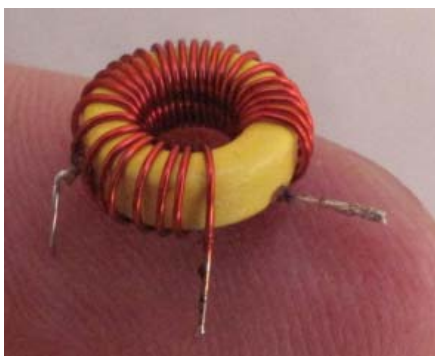

Figure 34. L9 VFO coil leads trimmed and formed.

□ Install L9 as shown below. The ends are soldered to pads 1 and 2, with the tap going to pad 3. The lead on **pad 1** needs to be soldered **flat to the top of pad 1** (not through the hole) in order to make removing turns easier, if needed. The other two leads are soldered “through hole” to 2 and 3.

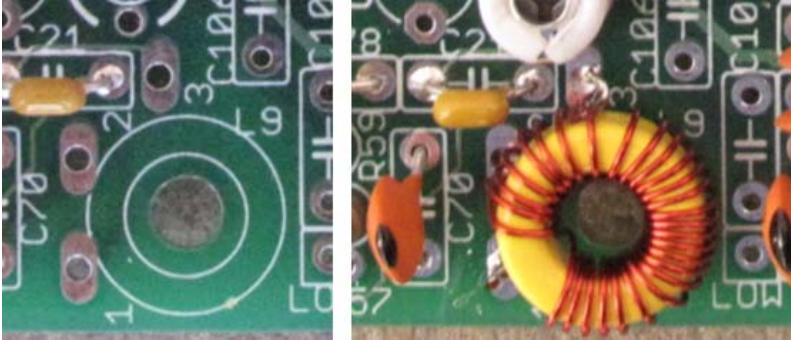

Figure 35. L9 mounted. Pads labeled 1, 2, and 3 are used as shown. Pad 3 is used for the tap.

- Install Q10, a 2N5485 JFET transistor

From this point on, the VFO should be running. It nominally runs in the 6 to 6.15 MHz range.

Make sure the RIT pot is in place! It is necessary to have the VFO operate properly.

VFO/TX Test2

- Connect a 12v power source and conduct the following tests:
- The current draw when connected to 12v battery will be in the **29** mA range.
- Disconnect the 12v power source.***

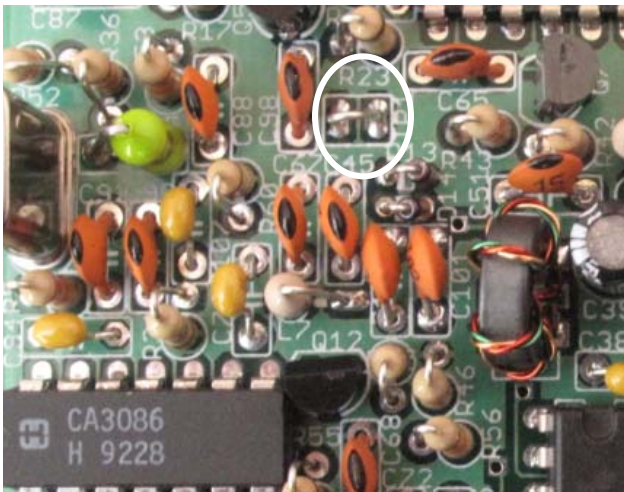

Figure 36. Wire loop installed at TP1, test point 1

- Install a loop of wire at TP1 as shown above. Refer to the parts overlay at the beginning of the section to locate TP1 (circled in red) if necessary.

TP1 is a test point that allows us to tune up the mixer band pass filter. This involves adjusting the yellow trim capacitors C40 and C96 installed above for a peak reading on a volt meter connected to this point. In the installation of C40 and C96, these trimmers were preset to roughly the right tuning point to

pass the 21 MHz VFO signal. When measuring the voltage across TP1 to ground (ground is any corner mounting hole except the one near the VFO and just installed Q10), peaking these two trim caps ought to give a DC voltage of between 1 to 1.5 V.

- Connect a 12 V power source and conduct the following tests:
- Peak trim caps C40 and C96 to maximize the voltage on TP1. Alternate several times between peaking one trim cap and then the other.
- After peaking, the voltage on TP1 should be between ~ 1 and 1.5 V DC.
- Disconnect the 12 V power source.***

Install the finals driver, 74AHC04 IC7. ***Make sure the notch on the IC lines up with the notch on the board! Do not install backwards!*** See the picture below. C46 near the notch may need to be pushed out of the way a bit since the fit is tight.

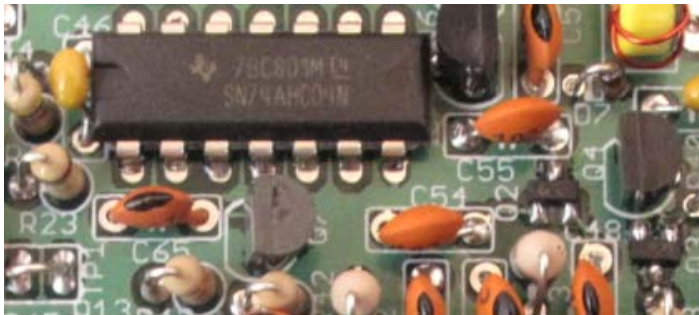

Figure 37. Installation of IC7, a 74AHC04.

Cut 6" of red enamel wire and wind L6 with 10 turns of wire (***counter-clockwise***) on a yellow T37-6 core. Remember, the first pass through the center of the core counts as turn # 1. Again, the holes in the PC board assume L5 is wound a certain way. The pc board pattern assumes that each turn is added from the ***bottom*** side of the core, and that the turns are added in a ***counter-clockwise*** direction around the core.

Tin the leads up to the edge of the core and mount L6 vertically as shown below.

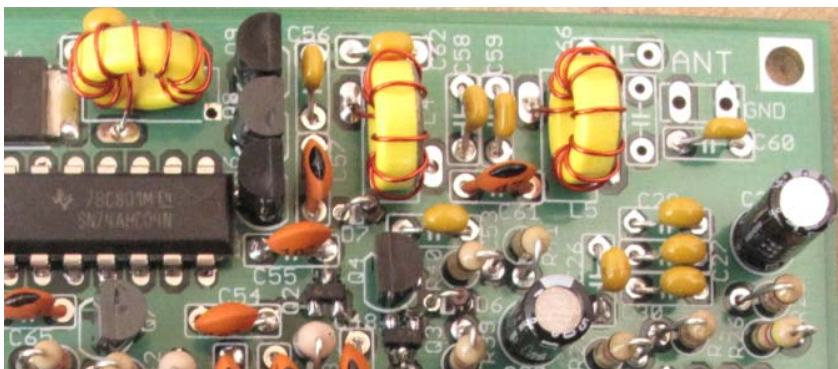

Figure 38. L6, L4 and L5 all mount vertically

VFO/TX Test3

- Connect a 12 V power source and conduct the following tests:
- The current draw when connected to 12 V battery will be in the **39.1 mA** range.
- Disconnect the 12 V power source.**

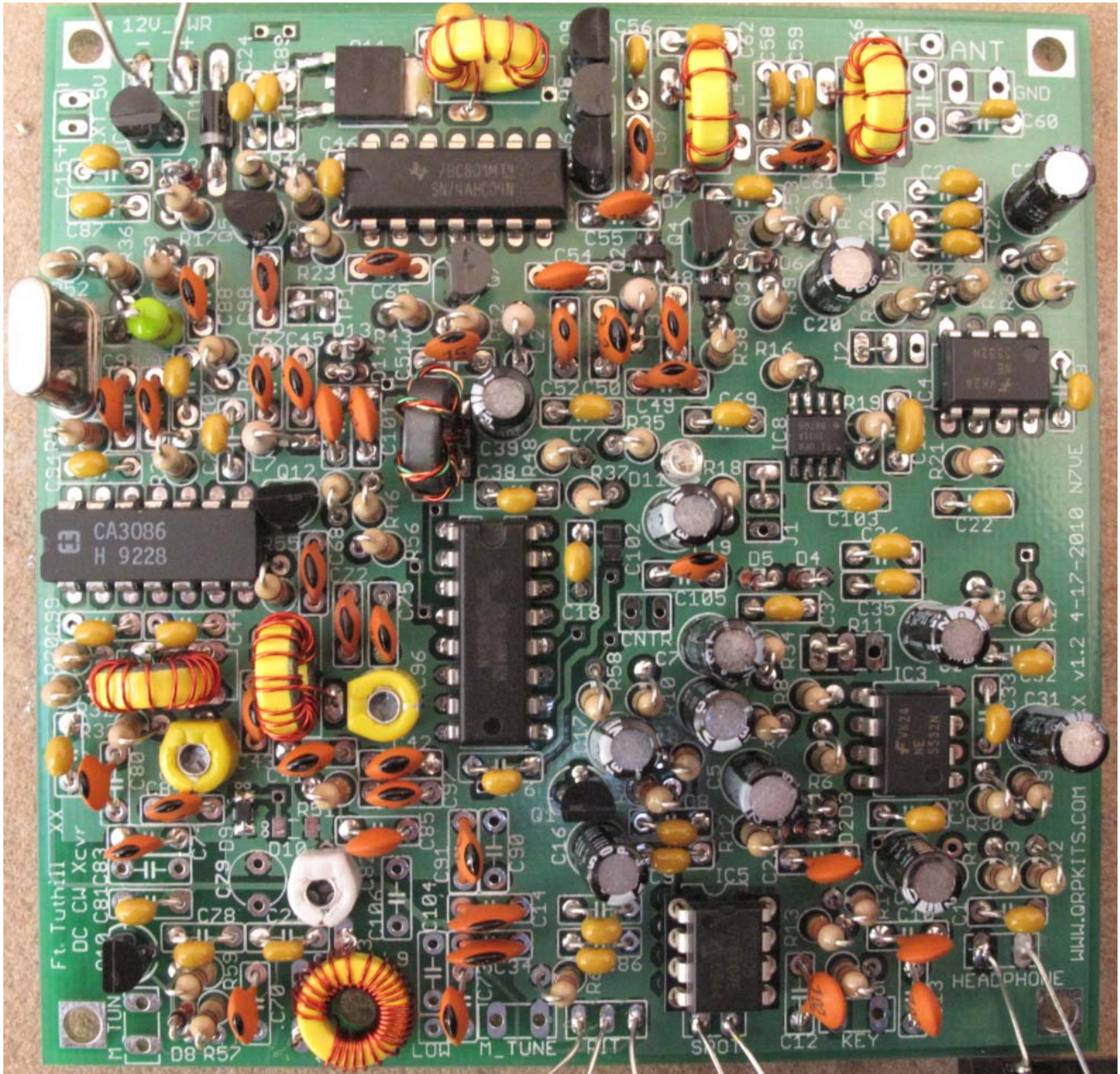

Figure 39. Finished PCB board

Transmitter LPF Tests

- Take an ohm meter and measure across the antenna terminals. If all is well, this should read as an open. If it does not, check for shorts in the L4 and L5 area.
- Also take an ohm meter and measure from the antenna input to the pad of L4 next to C62. This should show a short (0 ohms or very close to it) and verifies that L4, and L5 are all connected properly in series.

The board is now finished. However, at this point, it is time to roughly set the frequency of the VFO.

VFO alignment

The RIT pot must be in place for the VFO to operate properly!

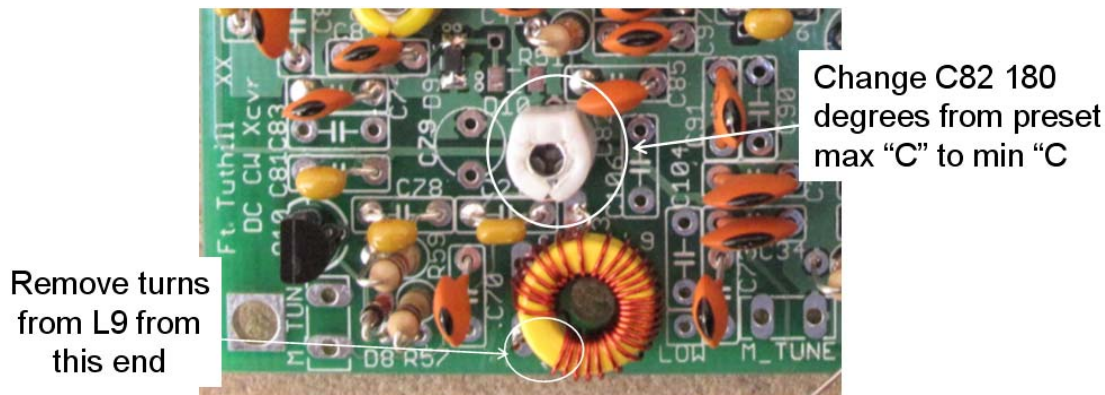

Figure 40. View of VFO area including trim cap C82 and L9

The simplest method of aligning the VFO is to use a frequency counter. The Digital Dial frequency counter is an available option for this kit. There is a built in pick off point for a frequency counter (such as the Digital Dial) shown below. Connect the frequency counter to the "CNTR" output pads just to the right of IC6, the 74LV4053. There is a built in 4.7 pF coupling capacitor for this output to minimize the loading on the VFO signal. If the Digital Dial frequency counter is added to the kit, this is the connection jack for the counter. The use of a frequency counter allows the receiver frequency to be measured directly

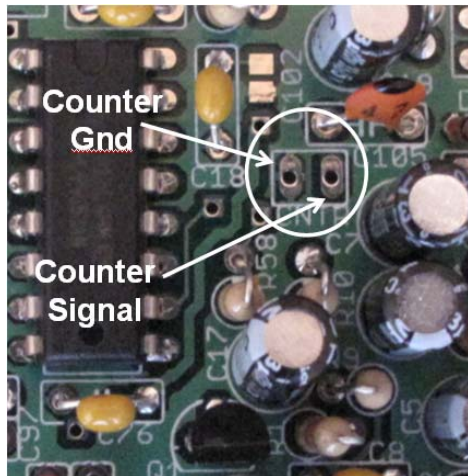

Figure 41. Suggested frequency counter pick off point for the receiver LO.

In all of my prototypes, all VFOs came up at around 21.100 MHz. If it is in the 21.00 to 21.2 MHz (like most are right out of the gate), the initial set up is done.

The final tuning of the VFO will need to be done with the board mounted in the case with the main tuning capacitor connected and the range switch (low tuning range/high tuning range) connected. However, at this point we do want to start with the receiver in the 15m cw area, roughly somewhere in the 21.000 to 21.150 MHz area. *Warning: mounting the board in the case will lower the VFO frequency quite a bit (100 KHz?).* At this point don't bother setting the VFO exactly on frequency.

The VFO is coarsely tuned in one of four ways:

- 1) Removing one turn from L9 from the 21T side of the coil (Pad 1) will raise the frequency by 180 to 190 KHz. We will try to avoid doing this.
- 2) If the turns on L9 are spread out more, the inductance will decrease, raising the frequency. Since the instructions were to wind L9 "shoulder to shoulder", the inductance should be maximized to start with (lowest frequency). This should be the only coarse adjustment needed for 99% of the kits.
- 3) If the frequency is too high, the white trim cap C82 can be used to trim the frequency. C82 seems to be set a maximum when delivered from the factory. If you look closely on the adjustment slots of C82, you will see an "arrow" formed. Turn this arrow a full half turn to point it to the flat side of the tuning capacitor to *set it to the minimum. Use only a little bit of C82 if you use it at all!*
- 4) Just as removing turns from L9 can be used to raise the frequency, two 8.2 pF capacitors have been included to lower the frequency. One 8.2 pF cap can lower the frequency by about 80 KHz. There are several spare capacitor positions on the VFO that can be used for these extra capacitors if needed. C79, C83, and C90 are unused VFO capacitor locations that can be used for these fix "trim" capacitors.

If you do not have a frequency counter, two other alternatives are:

- 1) The simplest way to do this without a frequency counter is to get a signal generator, like a DDS VFO, and use it to feed an insulated wire that is placed close to T1. If a signal generator is used, set it to a relatively large signal level such as -40 dBm. Now sweep the signal generator from 20.9 to 21.3 MHz until the signal generator signal is heard. You may need to search around a bit depending on exactly how many turns have actually been placed on L9. It is easy to be off by one or two turns out of 28 total.
- 2) Use a second 15m receiver to listen for the VFO using a section of insulated wire (18"?) placed near L8 which is just above and to the right of the CA3086. The normal case is that the VFO will be heard near 21.100, but you may need to listen around for the signal. It may be needed to remove one turn at a time from L9, listening for the VFO in the 21.00 to 21.200 kHz area. This last method will work assuming the VFO is running properly. Using a very short wire will make sure that all other signals on the band will be very weak, while the mixed VFO signal from L7 should be very strong. You will be able to tell that this signal is from the TUT-15 by moving the wire closer or further to L7. When you do this, the strength of the signal should change dramatically if this is indeed a signal from the VFO.

One small note on VFO stability. For best drift performance, I have found that VFOs need to be “broken in” for best VFO stability. I suggest leaving the rig on continuously for at least three days to accomplish this.

Transmitter Tests

A connection can be made to the antenna jack (“ANT” at the top right of the board) to allow a quick test of the transmitter before the board is placed in a case. The transmitter output power is fixed. With a supply voltage of 12 V, the kit should deliver approximately **5w** of output power into a 50 ohm dummy load. The current drain is approximately **760 mA at 12V**. 5w is the nominal output power. There is expected to be some power variation from kit to kit.

This transmitter is not designed for continuous key down operation, although it could likely survive such operation into a good 50 ohm load due to its high efficiency (the finals are approximately 72% efficient). At 5w of RF output, the finals are using about 7w of DC power, and each of the three BS170s are rated at 800 mW each. Thus, this is about 660 mW of heat per device.

The V2 PICF508 firmware has a “dotting” mode that kicks in after about three seconds of continuous key down to protect the finals from potential overheating. This reduces the TX to 1/3rd duty cycle to allow longer antenna tune up cycles not to overheat the transmitter.

The transmitter will survive transmitting for a brief time into an open load. However, prolonged transmission into an open load will burn up the BS170 finals.

The kit is now ready to be placed into a case.

Placing the Kit into a Case



Figure 42. Front panel view with decals applied and optional Digital Dial frequency counter



Figure 43. Rear panel view with decals applied

Chassis Preparation

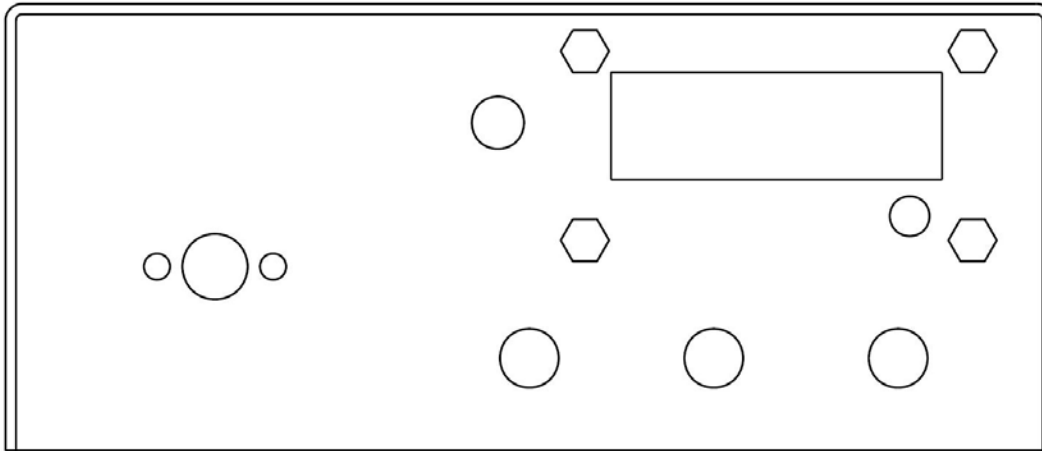

Figure 44. Drawing of the front panel before controls are mounted

The chassis supplied is furnished in a brushed aluminum finish. You may choose to leave it as is, or paint it. If you choose to paint the chassis, after cleaning thoroughly, we recommend a primer coat, sanded lightly, and then a finish coat in the color of your choice. If you chose to use the supplied decals, it is best to keep the front and rear panel, light in color, so there is contrast between the black decals and your painted surface. You can paint the cover the same color, or a contrasting color of your choice.

If you choose to leave the brushed aluminum finish, the PEM standoffs for the Digital Dial are installed after the chassis is grained, so it will be necessary to use a small piece of emery paper to blend in the small hex imprint of the PEM standoffs. Finish the grain in the same direction (horizontally) as the surrounding finish. Our display pictures on the web site show the chassis prepared in this method. This would be the coolest option, in the sun, if you are using the radio outdoors.

Decal installation

If the plain aluminum look is desired, the decals will need to be applied before the kit is mounted inside the chassis, because several light coats clear spray will be needed to protect the decals, and all the hardware needs to be removed before doing the spraying. It may be best to temporarily loosely attach controls and knobs in order to better see where to place the decals. Again, remove the hardware before applying the clear coat.

If the case is going to be painted, the painting also needs to be done before the controls, main PCB, or Digital Dial is added. When painting the cases, three *light* coats of enamel paint seems to work well. Wait an hour between coats. With each coat, the paint will be extremely soft and easily damaged. If you damage a painted surface, use steel wool to strip off all the paint and start all over. When done with the third coat, place the painted case in the oven at 180 to 200 degrees F for two hours. Place it on a middle rack with a pan above and below it to protect it from direct heat. Two hours at this heat will

harden the paint nicely. A picture of a painted case is shown below. When you point the case top, make sure to pain the underside back from the edge by 0.5". As you can see in the pictures below, some of the underside of the case top overlaps with the bottom and is visible.



Figure 45. Picture of decal locations on the front and back panels

The decals are applied the same as model decals. Cut around each group of text or symbols you wish to apply. It doesn't have to be perfect as the background film is transparent. Apply the decals before you mount anything to the chassis. Use the above picture to get the correct spacing around the holes and cutouts, as it is very easy to do a great decal installation and have a portion covered up with a knob

Thoroughly clean the surface of the panel to remove any oils or contamination. We have found that moving the decals into position on bare aluminum chassis is difficult, due to the brushed surface, so we advise pre-coating the chassis with the Krylon clear before applying the decals, and then, after as well.

Trim around the decal. After trimming, place the decal in a bowl of lukewarm water, with a small drop of dish soap to reduce the surface tension, for 10-15 seconds. Using tweezers, handle carefully to avoid tearing. Start to slide the decal off to the side of the backing paper, and place the unsupported edge of

the decal close to the final location. Hold the edge of the decal against the panel, with your finger, and slide the paper out from under the decal. You can slide the decal around to the right position, as it will float slightly on the film of water. Use a knife point or something sharp to do this. When in position, hold the edge of the decal with your finger and gently squeegee excess water out from under the decal with a tissue or paper towel. Work from the center, to both sides. Remove any bubbles by blotting or wiping gently to the sides. Do this for each decal, and take your time. Allow to set overnight, or speed drying by placing near a fan for a few of hours. When dry, spray two **light** coats of matte finish, Krylon, clear to seal and protect the decals, and allow to dry in between coats. *Using a first coat that is too heavy can cause the decals to shift. Keep the first coat light!* All decals come with two complete sets, in case you mess one up.

Connecting Jacks, Button, and Controls to the Case

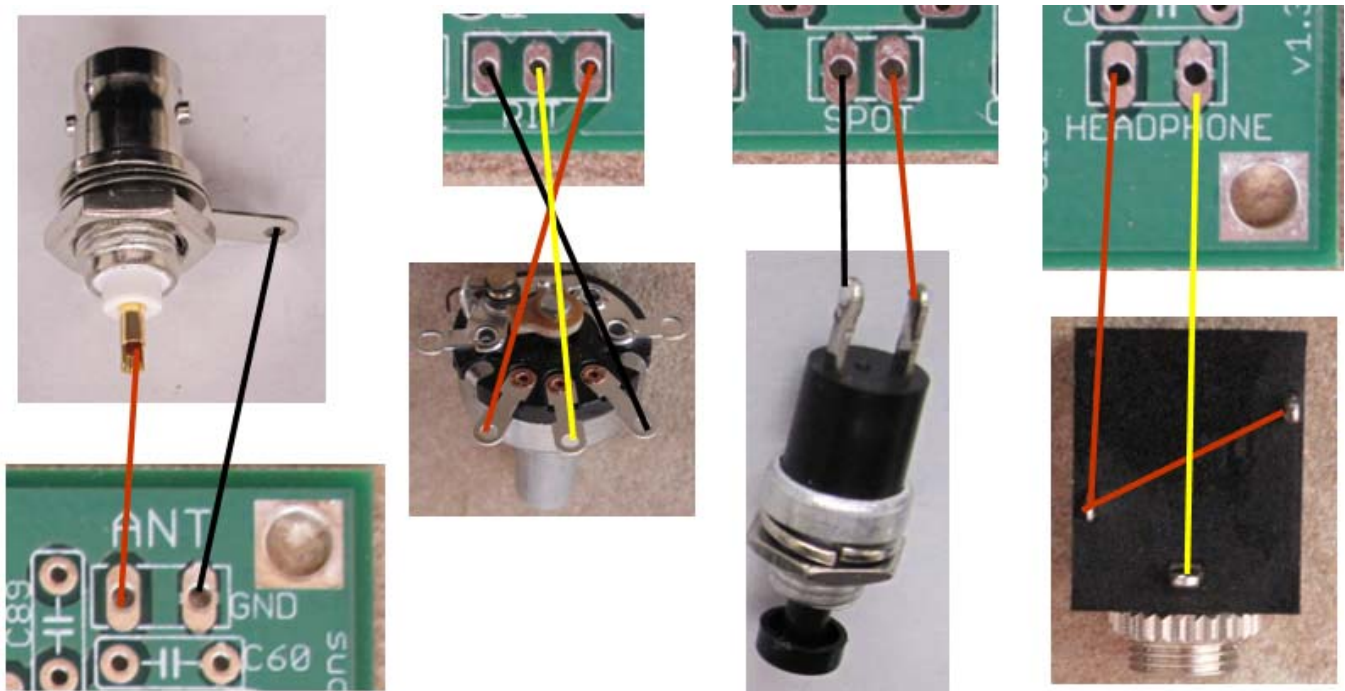

Figure 46. Visualization of Antenna, TX tuning pot, spot switch, and headphone connections.

The above picture shows how to connect the antenna jack, the RIT pot, the spot switch and the headphone jack to the board. Hook up wire has been provided to make the connections shown above. Note that the headphone jack is connected to the rear panel.

All rear connections (power, key, and headphone jack) should be routed around the outside of the standoffs (not under the VFO!) and the left edge of the board in order to keep them away from the transmitter power amplifier and antenna connection.

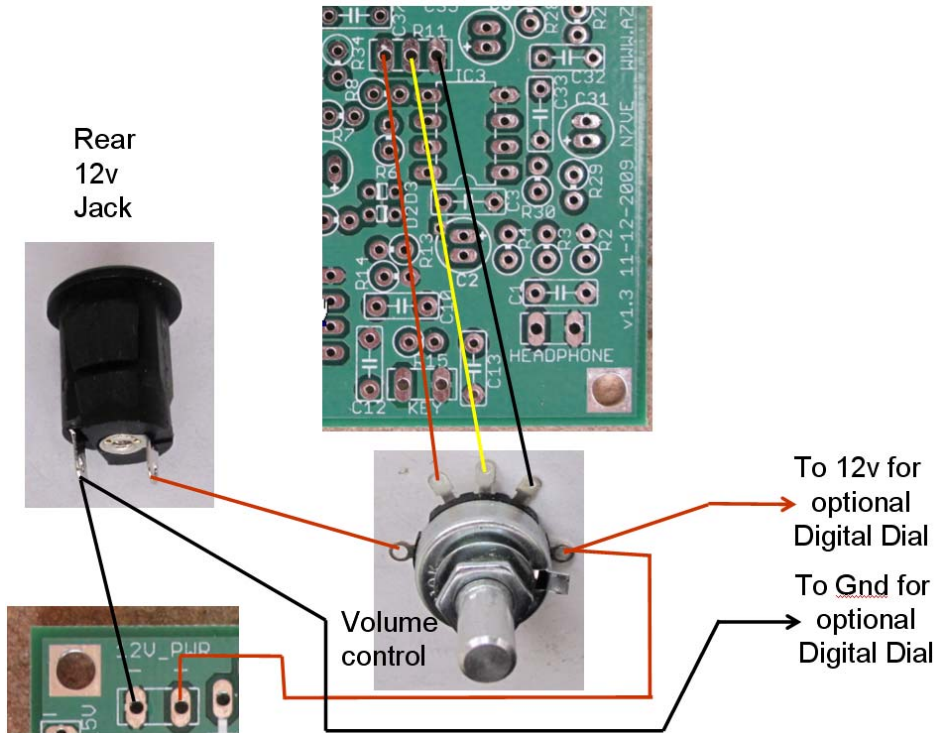

Figure 47. Visualization of 12 V power jack, volume control and Digital Dial connections

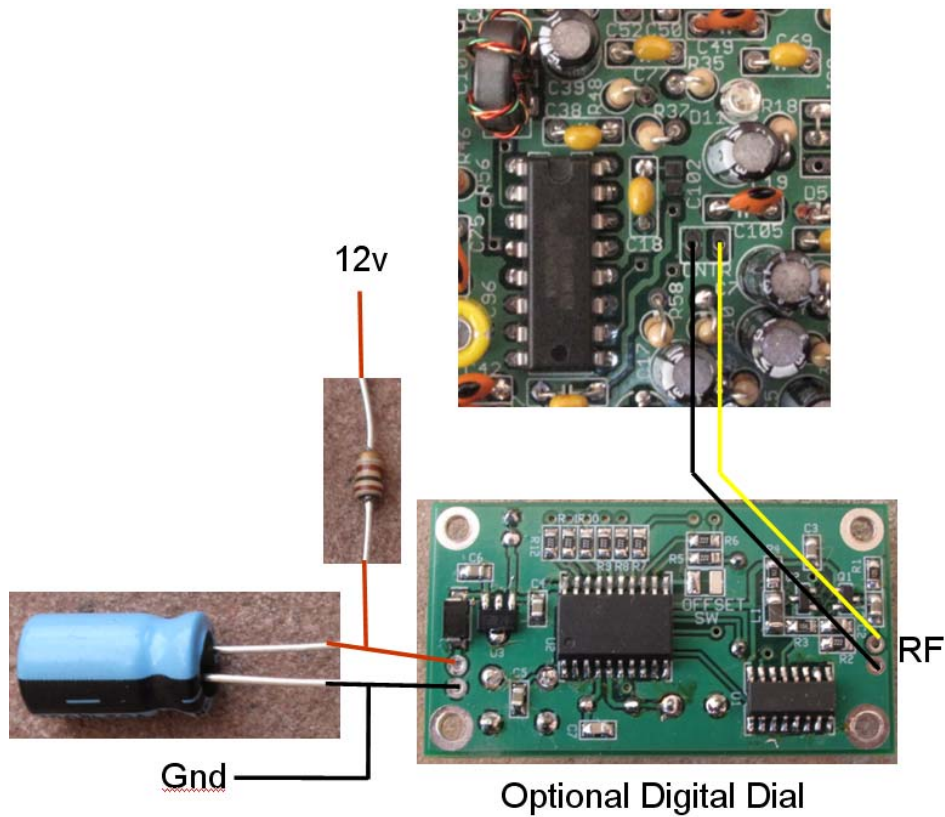

Figure 48. Optional digital dial and additional 12 V filtering, 100 ohm and 100 uF cap

The above picture shows how to connect the 12 V jack, volume control and the optional Digital Dial to the board (12v_PWR, CNTR and R11 PC board pads). The supplied hookup wire can be used on the 12 V power connections. The more compact left over enamel wire was used on the three connections from R11 on the board to the center three connects on the volume control. The picture below shows some of the extra tri-filar winding material used for the three volume connections.

Note: The three leads to the volume control and the two RF leads of the Digital Dial have a neater appearance if they are installed from the bottom of the board, rather than from the top side as shown in the diagram above. Leads on volume control need to be bent over if an optional Digital Dial frequency counter kit is installed. A picture of the bent volume control leads is shown below along with a picture of the volume control as installed right below the Digital Dial kit.

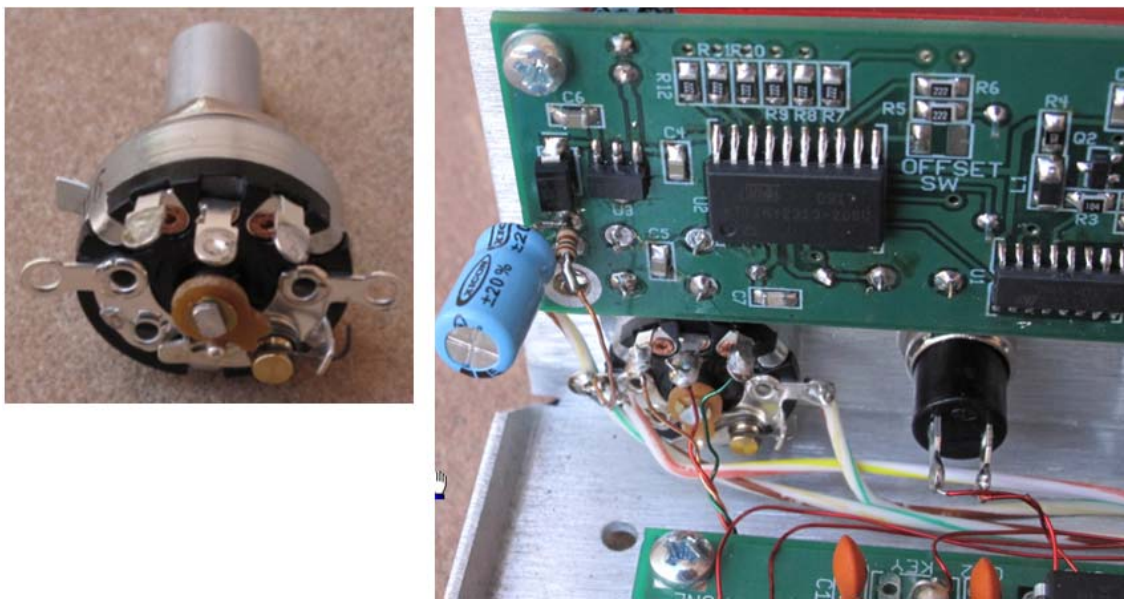

Figure 49. Volume Control tabs bent to provide clearance for optional Digital Dial

The above picture of the installed volume control shows the 12 V power switch portion of the volume control close to the case. ***Make sure the volume control is installed with the power switch tab horizontal (as shown!) to prevent the 12 V power from shorting to the case!***

The above picture also shows the extra 100 ohm and 100 uF 12 V filtering. The filtering is needed to clean up display multiplexing noise from the Digital Dial from getting into the receiver audio. The leads on the 100 uF cap are folded over and solder on the top side of the 12 V power pads . This 100 uF capacitor must face to the rear of the case to fit inside the chassis.

Whether or not a Digital Dial is purchased, the red plastic bezel needs to be installed. Place the bezel on the mounting posts for the Digital Dial and mark exactly how much plastic needs to be removed to get the bezel to fit over the posts and around the Digital Dial push button hole. The picture below shows the bezel as trimmed with a pair of scissors using square cutouts

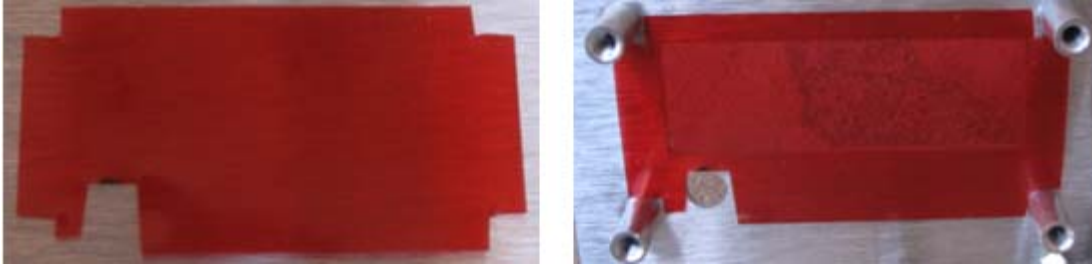

Figure 50. Trimmed red plastic bezel and shown mounted in place

When the Digital Dial is used, the bezel does not need to be secured as the mounting of the Digital Dial behind it and the bezel cut outs around the mounting posts seem to hold it into place. If a Digital Dial is not in place, it is suggested that a rigid piece of cardboard (such as from the box the kit came in) be placed behind the bezel (cut to match the bezel and its cut outs). The backing should then be taped into place using scotch tape.

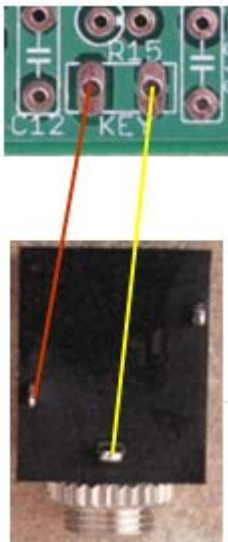

Figure 51. Visualization of TX key jack

The above picture shows how to connect the TX key jack to the board. Later picture show this jack connected to the rear panel of the chassis. In those pictures, the headphone jack uses its own two lines (including ground). The key line shares the ground with the key jack as shown below.

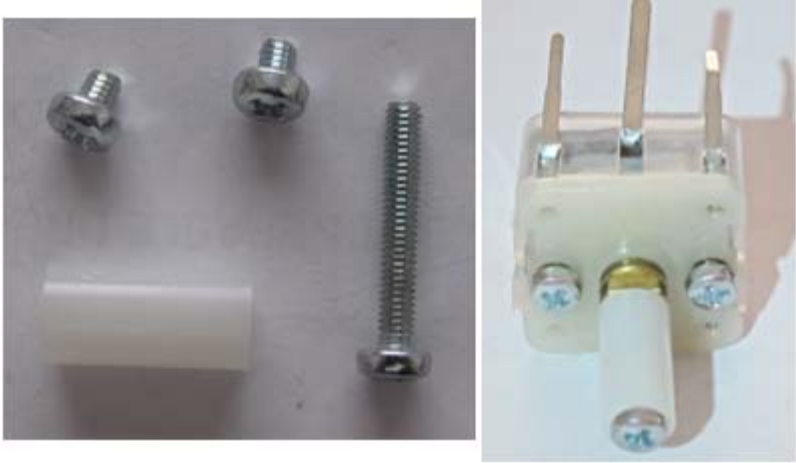
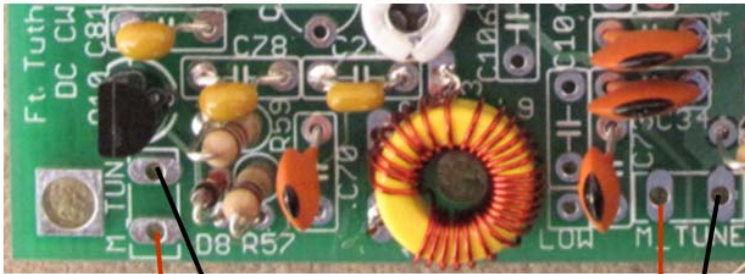

Figure 52. Mounting hardware for the main tune capacitor

The above picture shows the main tune capacitor with its mounting hardware. The long screw is used to attach the 1/4" nylon sleeve to the main tune shaft so that a normal 1/4" shaft knob can be used to tune the receiver. If the small mounting screws are added to the tuning capacitor before it is mounted to a front panel, beware that tightening the screws can cause them to go too deep into the capacitor body and damage the interior of the capacitor. Once mounted on a front panel, this will not be a problem.



Nominal
55 KHz
range



Hi/Low
Band
Switch

Figure 53. Connection of main tune capacitor and Hi/Low band Switch

This kit uses a 1.5" main tuning knob. 55 kHz of total tuning range in a half turn if a 1.5" knob seemed to work well, so the kit has been designed to operate in two tuning ranges of 55 KHz. This is nominally 21.000 to 21.055 for the bottom tuning range. The upper tuning range depends on how the Hi/Low band switch is set up. As shown above, there 8.2 pF (C73) that is switch into and out of the circuit. 8.2 pF provides ~ 73 KHz of offset between the high band and low band. Thus, this configuration would cover 21.073 to 21.125 MHz.

However, the F1st calling frequency is at 21.058 MHz and the QRP calling frequency is at 21.060 MHz. Thus, an alternate arrangement for the band switch is to take the one unused 15 pF disc capacitor and place it in series with the Hi/Low band switch as show below. This picture actually shows two 8.2 pF caps in parallel, but we will use the one extra 15 pF cap in place of that. This reduces the distance between the two ranges to about 45 KHz, so that with this change, the Hi tuning range is 21.045 to 21.100 MHz. This allows ample space around both the QRP and F1STs calling frequencies.

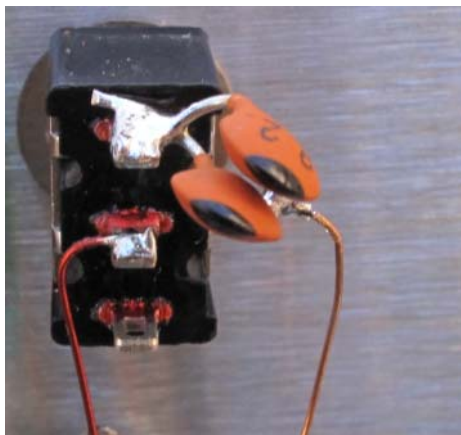

Figure 54. Option to set Hi range to cover 21.045 to 21.000 MHz. Use a single series 15 pF cap.

The 15 pF series cap on the band switch as shown above is the preferred band switch configuration for the TUT-15, providing coverage from 21.000 to ~21.100 MHz in two bands using with a good tuning rate.

It is very important that the center terminal of the main tuning capacitor is connected to ground as shown above. Likewise for the band switch. If either of these two are hooked up backwards, there will be “hand effects” where moving your hand near these controls shift the frequency.

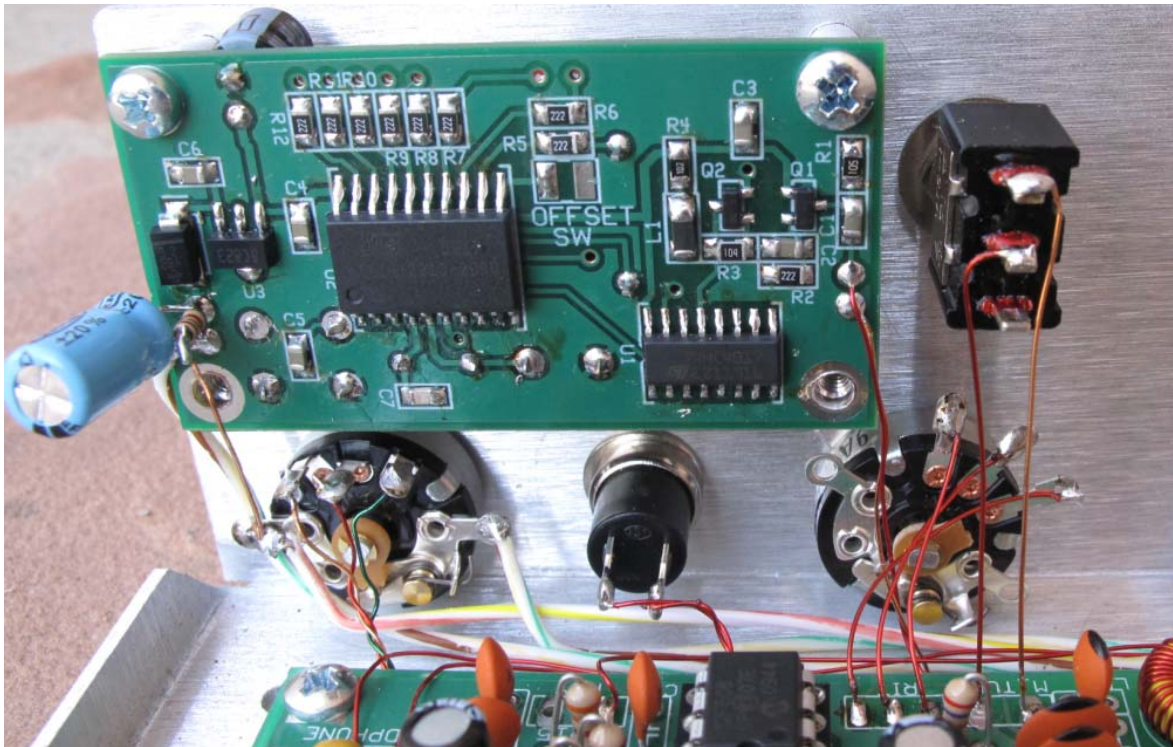

Figure 55. RIT, Spot, Hi/Low Band Switch and optional Digital Dial RF connections (right side)

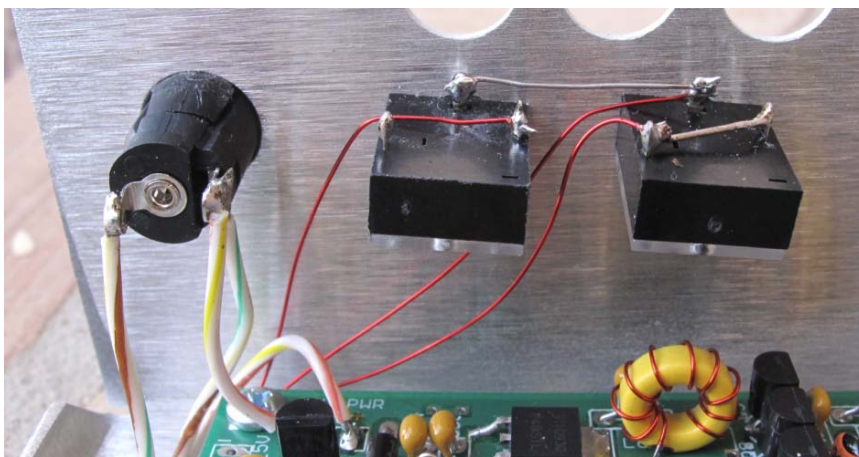

Figure 56. Power jack connections, headphone and key jack connections.

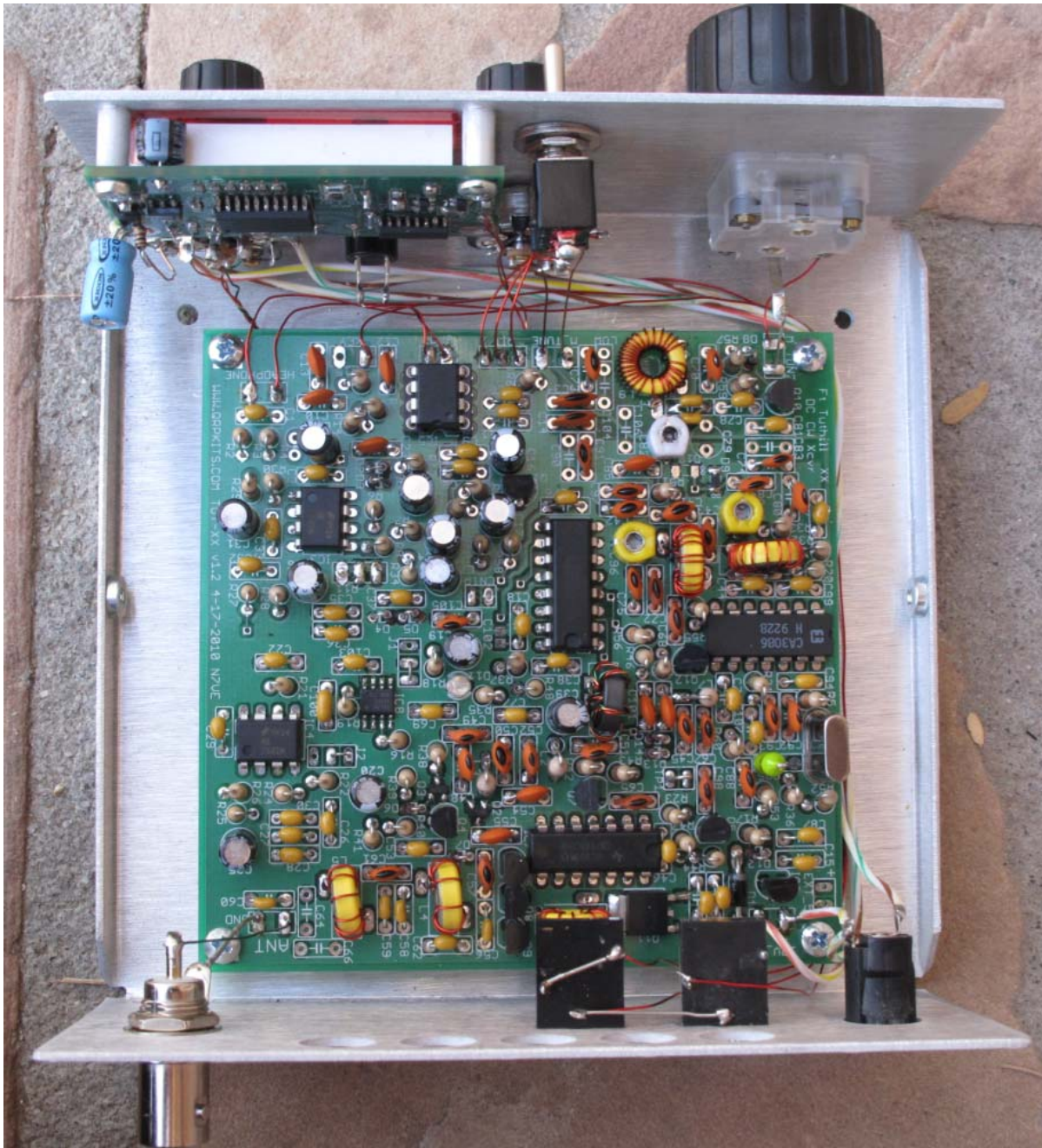

Figure 57. Board in case. All front to back wires routed along the CA3086 edge of the board

Final frequency tweaks

After the kit is placed into the chassis, final frequency adjustments can be made. This final alignment involves two parts. The first part is setting the VFO on frequency, and the second part is adjusting the mixer bandpass filter to peak one trim cap at the top edge of the tuning range (high range, highest frequency).

Adjusting the VFO involves switching the Hi/Lo band switch to the low side and then adjusting the lowest frequency of that range to be 21.000 MHz. Earlier sections covered how to tune the VFO. Most of these adjustments will involve compressing or spreading the turns on the VFO coil L9. Earlier, C82, the white trim cap, was set to its minimum value. We want to use only enough of C82 to get perhaps 4 or 5 KHz of fine tune adjustment, although it is good for 80 KHz or so. Trim caps such as C82 can degrade the stability of the VFO, so it should be used as little as possible, kept near its minimum value.

If adjusting L9 cannot get the VFO to 21.000 at the bottom end of the low range, removing a turn of L9 will raise the frequency by ~180 KHz, while adding a fixed 8.2 pF, will lower the frequency by ~80 KHz. Removing a turn from the pad 1 side of L9 should be considered only if spreading the turns on L9 fails and the frequency is too low.

Once the low frequency range has been set, the high frequency range is whatever it turns out to be. The final adjustment is then to tweak yellow the mixer bandpass filter trim caps while monitoring the DC voltage on TP1 (see the earlier VFO section). The goal is to get at least 1 V on TP1 over the entire tuning range, although 0.7v seems to be plenty. One trim cap should be peaked at the high end, and the other at the low end. Go back and forth several times.

At this point, we are done and the transceiver is ready for use.

A few tips on using the transceiver

How "spot" and RIT works

First a description on how the RIT and "spot" works. The VFO has a varactor diode, D9, that is used to provide offset tuning to the VFO. The blue LED is used as a 2.8 V shunt voltage regulator. During **transmit**, the VFO varactors are supplied this **fixed 2.8 V voltage** via one of the three analog SPDT switches in the 74HC4053. This sets the transmit frequency somewhat mid way (2.8 V) in the 1.25 to 5 V varactor tuning voltage range.

In other simple rigs, this "mid range" TX voltage is normally just set using two resistors as a simple voltage divider off the 5 V supply. However, the use of the blue LED is used to stabilize (regulate) any small voltage changes out of the 5 V regulator. The voltage out of the 5 V regulators can shift a bit as the current demands change and the input supply voltages droop on transmit. These transmit voltage variations in the 5 V supply has caused TX "chirp" on some rig designs in the past. The use of the blue LED, providing enhanced 2.8 V regulation is just additional insurance against TX chirp.

Recapping, the 2.8 V from the blue LED sets the TX varactor voltage to mid tuning range. When the rig is **receiving**, the varactors are fed a **variable voltage from the RIT pot** which allows the varactor voltage to be set anywhere between 1.2 and 5 V. Since the RIT voltage can be set either above or below the fixed 2.8 V used by the transmitter, the receiver can be tuned higher than the transmitter frequency (2.8 to 5 V) or lower than the transmit frequency (1.2V to 2.8V). There is roughly 1.8 kHz of tuning range on one side of the TX frequency and 3 kHz on the other, so things are not exactly centered, but I have a limited selection of LED colors to choose from and thus a limited selection of resulting TX voltages.

When you press the "spot" switch, the timing processor (the PIC12F508) switches the 2.8 V blue LED voltage into the varactor diodes and sends a brief short "beep" once a second to remind you that you are in the "spot" mode. At this point the receiver is set dead on the transmit frequency. In the "spot" mode, if you zero beat another stations (i.e., reduce the frequency of his tone until it goes to zero Hz), when you transmit, you should be sending exactly on his frequency. In the "spot" mode, the RIT pot does nothing as it is disconnected from the varactors.

When you are in the "spot" mode, and you are hearing 1 second brief beeps, if you press the "spot" a second time, an "R" (which indicates RIT mode as opposed to "X" for XIT mode) will be sent and the fixed 2.8 V TX voltage will be replaced with the variable RIT pot voltage. At that point, you can vary the RIT knob, and you will notice that you can tune the station that you zero beated in the "spot" mode to a comfortable listening tone (like 600 Hz) in *two places* in the RIT tuning range. *Note where these two places are.* RIT will normally be set to one of these two positions. One of the two positions is listening *above* your transmit frequency (+600 Hz?), and the other one is listening *below* your transmit frequency (-600 Hz?). As you tune across the band and hear a station you want to work, you will need to use one of these two RIT positions to place the TX directly on top of his signal. However, only one of two positions will place the TX in the right spot, and that depends on whether you are listening to a signal above or below your TX frequency.

Figuring out which RIT offset to use takes a little bit of practice. Practice tuning across the band and checking if you have the RIT set right. When tuning across the band from the low side of 80m to the high side of 80m, you probably want to listen on one side of zero beat for the arriving station as it moves from a high frequency to a listenable 600 Hz. When moving from a high 80m frequency to a low 80m frequency and you hear an arriving station moving from high frequency to a listenable 600 Hz, you will want to use the other RIT tuning point. When you don't know what to do, use "spot" to zero beat the station, then undo "spot" and use the RIT to tune to a listenable tone.

Play with things for a while and I think you will get the hang of knowing if you are listening to the station on the right side so that your TX signal will be in the right place. When in doubt, "spot".

How "spot" and XIT works

The above description describes how spot and RIT works. The "V2" PIC12F508 firmware has been upgraded to also perform XIT. In the spot procedure above, pressing the spot button once briefly entered the spot mode, which could be identified by the 1 second periodic "clicks". Press the spot briefly a second time and "R" (RIT mode) would be heard, and spot mode would be finished.

In the above procedure, there are two button presses required total, one to enter and one to exit spot mode. If the spot button is pressed and held for 2 seconds or more, the mode will change. "X" (XIT) or "R" (RIT) will be sent depending on if the XIT or RIT mode is currently active. If the spot button is pressed and held for a long time, spot will simply cycle between "X" and "R" every two seconds. When the spot button is released, the mode last reported will be used. This XIT/RIT mode change can be done any time the spot button is pressed and held. In other words, it can be done when entering spot mode or when leaving spot mode.

When exiting spot mode, spot will send either “R” or “X” to tell you which mode it is using. Thus, if you are unsure which mode you are in you can quickly enter and exit spot mode, and upon exiting spot it will send either “X” or “R” to indicate which mode it is using.

XIT works backwards from RIT as described in the earlier section. In XIT, the receive offset is frozen. The XIT/RIT tuning knob does nothing in the receive mode. The fixed offset discussed in the RIT section above is used. In the transmit mode, the XIT/RIT tuning knob is used to adjust the location of the transmitter.

XIT is useful when working a station that is receiving others using an offset. One example that comes to mind is working a DX station in a pile up. The frequency of the DX station is not changing. Thus, in the XIT mode, the fixed frequency of the XIT mode means that during receive, the receiver would be locked to listening to the DX station. Then in spot mode, you could search and find who the DX station is working and zero beat that station (or offset slightly from that station), and you will have set up the transmitter at an optimum place to be the next station to work the DX station. With the receive side set on the DX stations frequency, XIT allows you to use the spot mode and the XIT/RIT tuning knob to “chase” the frequency of the stations the DX station is currently working as he moves up and down the band working other stations.

In normal cw conversations or calling CQ the RIT mode is the most commonly used mode. Because of this, the RIT mode is the default when the transceiver is powered up. However, chasing DX can be quite fun (especially on 15m!), and the XIT mode is particularly useful for that.

Using RIT to escape QRM

Now if you are in a QSO with a station, and another station pops up and QRMs you, this could be a station on the opposite sideband of the sideband you are listening to. If this is the case, you can get rid of the station by quickly flipping the RIT from one sideband tuning spot to the other. Remember above the suggestion to mark where the two 600 Hz points are on your RIT tuning range. If you flip from the one position to the other, your transmitter frequency will not have moved. This will only work if you are in the RIT mode, not the XIT mode. In addition, the signal you are listening tune will be at the same pitch as before. However, your opposite sideband will have moved quite a bit and if the interfering signal was on the opposite sideband he will be gone. Now, in doing this you may have moved a different interfering signal to the new opposite sideband position, but at least you have options.

If the interfering signal was in the sideband that you were using, changing to the opposite sideband by using the RIT knob will not get rid of him, but something else will happen. If the interferer was higher in frequency than the station you were listening to, he will now be lower in frequency than the station you were listening to. Likewise if he was lower infrequency before, he will be higher in frequency afterwards. The receiver filtering is designed to attenuate low frequency signals. This was primarily aimed at reducing any potential 60 or 120 Hz hum. However, if an interfering signal is on the low frequency side of the station you are listening to or if it can be moved to the low frequency side by flipping sideband settings on the RIT, you do have the option of adjusting the RIT such that the interferer is closer to zero beat, thus attenuating him. The desired signal might be lower than what you would normally listen to, but QRM reduction is always a good thing.

Like I said, tune across the band, play with the RIT, and see what flipping from one sideband to the other using RIT does in separating two signals from each other. *It is good to have options!*

What RIT setting to use when calling "CQ"

In a lot of simple QRP transceivers, the "RIT" RX/TX offset is fixed to ~ 600 Hz. As mentioned above, when calling "CQ" the RIT mode should be used rather than the XIT mode.

When using the RIT mode, the TX frequency offset is fixed and the receiver frequency is variable due to the RIT offset tuning. If you are going to call CQ using the RIT mode, you will need to set the RIT knob at one of the two 600 Hz offset points (+/- for personal preference) so that when someone answers dead on your calling frequency, you will hear them at your preferred pitch.

The way you figure out where these two offsets are in your RIT tuning range is to find a signal on the band and "spot" him. By this I mean you turn on the spot mode by pressing the "spot" button, at which time you will hear a brief "beep" once a second to let you know that "spot" mode is active. In the "spot" mode, tune the target signal with the main tuning knob (the RIT does nothing in the spot mode) so that its signal tone goes all the way down to 0 Hz. Now undo the "spot" mode by pressing the spot button again (you will hear a cw "R" to let you know the spot is canceled). Now tune the RIT knob and find the two points where the signal is at a comfortable receiving tone. Remember these two points on the RIT dial. Mark them if you need to.

Now that you know where these two RIT tuning points are on your RIT tuning range, set the RIT to one of these two points when calling CQ. It does not matter which of the two offsets you use. If someone then answers your CQ dead on your calling frequency, he will end up at the tone offset that you want. The fact that most folks answering you do not know how to respond exactly on your frequency means that you may want to touch up the RIT setting to get the responding station at your preferred received CW pitch.

Unless you specifically want to work a station with a split offset (like a DX station in a pile up), you should normally have your RIT set to one of the two offsets identified above. After a QSO has begun, the RIT can be tweaked to set a station who is not exactly at your desired pitch to the pitch you want.

"Key down" transmitter protection mode

you key down too long, nominally 3 seconds, the transmitter will start sending a string of dots just to keep the heat down on the final. If your cat bumps your key and your transmitter is left going all day, your finals will not over heat, and everyone on the band will probably know it is just a TUT-15 stuck key down. If this mode did not exist, you might come back to a puddle of plastic for finals and this is one simple mechanism to keep that from happening. When you are tuning up the antenna and the TX goes into dotting mode, you can stop TX dotting mode by letting up on the key up for a second, which resets the 3 second timer.

"V2" sign on message

“V2” is sent when the receiver is turned on. This primarily tells you that the software version in the PIC12F508 is version 2 of the software which has been upgraded with XIT mode over the V1 version. If the software is ever changed, the next version will report “V3”. In addition, the sign on is used as a debugging diagnostic during the build to let the builder know that the chip and the last stage of the audio amplifier is operating as expected. If the software version were to ever change, this would let you know which software version you have.

When you turn on the receiver, it seems to take quite a while (~3 seconds) for the “V2” message to be sent. This is because it takes some time for the bias on the op-amps to charge up via their R/C bias network, and if the “V2” were sent any earlier, it simply would not be heard.

In the build it was suggested that the PIC12F508 be socketed. This is because there might be upgrades to the software in the future that you may or may not be interested in. The best IC sockets use round “machined” pins rather than flat, stamped, leaf spring pins. ICs have been known to work their way out of the inexpensive leaf spring type sockets.

A note on headphone sensitivity

You will not get any more volume out than you had in the testing phase of the receiver as the volume was wired to run wide open.

I have a variety of headphones. The least sensitive commonly available headphones have a sensitivity of **90 dB SPL/mW** although I have seen some as low as **86 dB SPL/mW**. Middle of the road headphones have a sensitivity of **100 to 106 dB SPL/mW**. High sensitivity headphones (these tend to be ear buds) are in the **108 to 112 dB SPL/mW**.

My bottom of the line Koss over the ear headphones fall into the 90 dB range and they do indeed sound weak. I have some old Radio Shack "on the ear" types in the 104 dB range and they sound great. I have not tried my Koss "the plug" ear bud types (112 dB), but they would be hotter yet. Notice that "medium" performance headphones will be ~ 14 dB louder than low performance headphones. This is a big difference. Also note that there is a **26 dB span** between the least sensitive headphones and the best ear buds. That is a very big difference.

Bottom line is that great magnets seem to be necessary for reasonable headphone performance. Inexpensive magnetics seem to produce insensitive headphones.

I would suggest going to Best Buy or Wal-Mart and checking the specifications of various headphones. I notice that some headphones cheat and specify xx dB SPL **per 1 Volt** (I have seen 116 dB), which is not at all the same scale as xx dB SPL/mW. It just a way to make 102 dB SPL/mW headphones appear much better than they really are. Let the buyer beware.

If your receiver audio output seems way low, find something that you like in the 102+ dB range and you will be surprised how much more audio you get out of the receiver.

Rig problems: Dead TX plus Howling Receiver – The HSOD

In building my prototypes, I have accidentally shorted out the 11 V filtered supply provided by Q1, a 2N3904. When this happens, the supply voltage on IC4 goes low (check pin 8), much lower than 11 V (like 5 V or so). At that point, the IC4 will oscillate producing a “howl” in the receiver audio.

The receiver howling/dead TX is a classic symptom that Q1 is now toast. It is very easy to do and I have managed this twice now across my multiple prototypes. With no 11 V, there is no TX, no RX and the receiver audio howls. I call it the Howling Squeal of Death (HSOD), kind of like the Microsoft Windows BSOD (Blue Screen of Death).

Q1 was designed as a separate transistor from the CA3086 package specifically so it can be easily replaced just in case this particular problem happens. A 2N2222, 2N4401, another 2N3904, or most any generic NPN transistor will work for Q1 as long as you keep the pin out the same.

Simply replace Q1 and you are good to go. It is a problem that seems much worse than it actually is and is relatively easy to fix.