

The DCxxA family of transceivers

High performance Direct Conversion transceivers for 40, 30 and 20 meters.



DC30A transceiver

Evolution of the popular DC40 to the DCxxA series on 40,30 and 20 meters

A KD1JV "Melt Solder" design
Distributed by Hendricks QRP KITS
www.qrpkits.com

Join Yahoo's DC40 kits group for support from other builders and information and modifications. Be sure to include your call and real name with your request.
[Http://groups.yahoo.com/group/dc40kits](http://groups.yahoo.com/group/dc40kits)

Steve and Doug wish to thank Chuck Carpenter, W5USJ for manual editing and revisions. Also our thanks to Jay Bromley, W5JAY, Tony Fishpool, G4WIF and David Yarnes, W7AQK for kit testing and manual proof reading

The DCxx is a moderately complex rig which yields excellent performance, yet is small enough to fit into an Altoids tin. The receiver features nearly complete immunity to AM SWBC interference and can be run on an AC supply with little hum pickup or AM BC interference common to most DC receiver designs. One stage of audio band pass filtering gives the receiver some selectivity. The transmitter puts out a respectable 750 mw of power with a 1.2V supply and over 1 watt with 13.8 volts. The transmitter frequency is automatically shifted up about 600 Hz to provide the proper T/R offset. The rig also includes a simple keyer.

Assembly:

Assembly of the board will be done in several groups. You can test most of these stages when finished, or move onto the next group and test everything at once. If a group fails to pass the smoke test, see the trouble shooting section located after the assembly instructions.

If you plan on installing the board into an Altoids tin, trim off the corner of the board next to the paddle jack before you install the jack. You may also want to mark where the mounting holes and where the phone jacks will be in the tin before installing any parts.

The parts location diagram for the whole board is shown below. Component values are marked in red. Experienced builders should be able to build up most of the board using just this diagram.

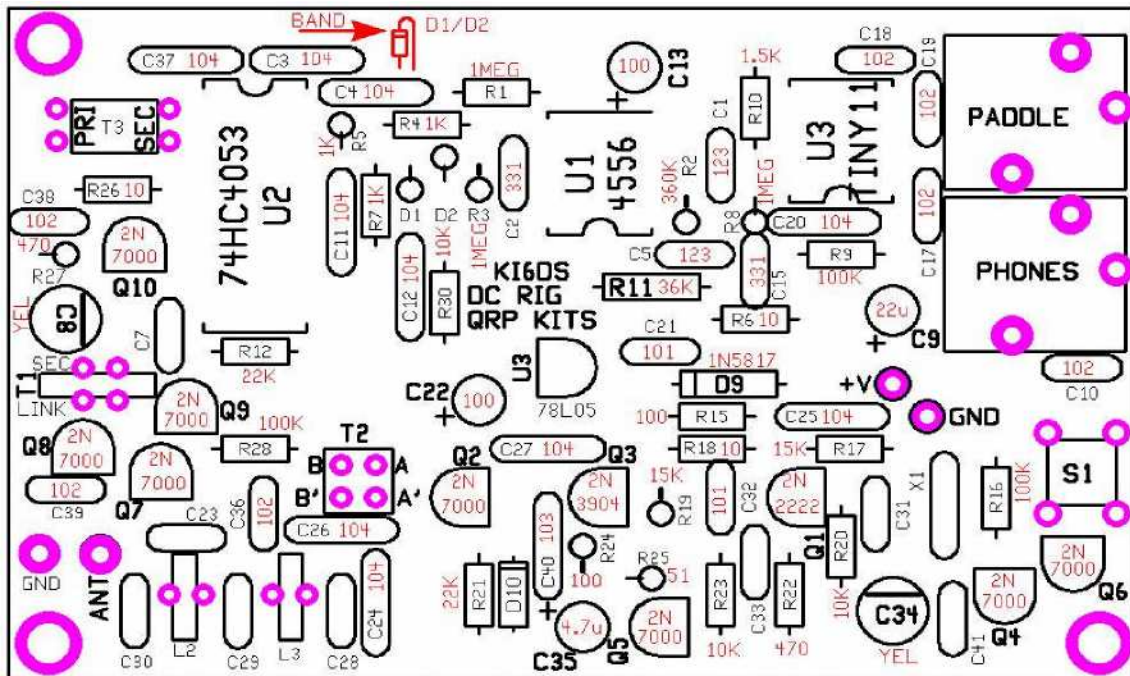

NOTE: PARTS WITH VALUES NOT SHOWN ARE BAND SPECIFIC.

U3, TINY11 has been replaced with TINY13.

Parts list

<i>RESISTOR</i>	<i>VALUE</i>	<i>TYPE</i>	<i>Caps</i>	<i>Value</i>	<i>type</i>
R1	1 meg	5% 1/4w CF	C1	.012 uF	FILM
R2	360 K	1.00%	C2	330 p	DISC or mono
R3	1 meg		C3	.1 uF	.2LS MONO
R4	1 K		C4	.1 uF	MONO
R5	1 K		C5	.012 uF	FILM
R6	10 OHMS		C6	Skipped	Not used
R7	1 K		C7	Band specific	See page 5
R8	1 MEG		C8	40 p	YEL TRIMMER
R9	100 K		C9	22 uF / 16V	ALUM
R10	1.5 K		C10	.001 uF	DISC
R11	36 K	1.00%	C11	.1 uF	MONO
R12	22 K		C12	.1 uF	MONO
R13	Skipped	Not used	C13	100 uF/16V	ALUM
R14	Skipped	Not used	C14	Skipped	Not used
R15	100 OHMS		C15	330 p	DISC or mono
R16	100 K		C16	Skipped	Not used
R17	15 K		C17	.001 uF	DISC
R18	10 ohms		C18	.001 uF	DISC
R19	15 K		C19	.001 uF	DISC
R20	Skipped	Not used	C20	.1 uF	MONO
R21	Skipped	Not used	C21	100 p	DISC
R22	470 ohms		C22	100 uF/16V	ALUM
R23	10 K		C23	Skipped	Not used
R24	100 OHMS		C24	.1 uF	MONO
R25	51 OHMS		C25	.1 uF	MONO
R26	10 ohms		C26	.1 uF	MONO
R27	470 ohms		C27	.01 uF	.2LS
R28	100 K		C28	Band specific	See page 5
			C29	Band specific	See page 5
L2/3	Band specific see pg 5		C30	Band specific	See page 5
T1	T37-2	Red	C31	Band specific	See page 5
T2	FT37-43	Black	C32	100 p	DISC
T3	BN-43-2402		C33	Band specific	See page 5
			C34	40p	YEL TRIMMER
			C35	4.7uF/16V	ALUM
			C36	.001 u	disk
			C37	.1 u	mono
			C38	.001 u	disk
			C39	.001 u	disk

			C40	.01 u	mono
			C41	100 p	disk
			SEMI'S		
X1	crystal		U1	NJM4556AD	High current opamp
SWITCH	6mm TACT	14mm shaft	U2	74HC4053	Analog multiplex
			U3	ATTINY13	MPU
			U4	LM78L05	
JACKS	PC mount stereo				
PC Board			Q1	PN2222A	NPN
Red and Green	Magnet wire		Q3	2N3904	NPN
2- 8 pin IC	sockets		Q2/4/5/6/7/8/9	2N7000	Tfet
			Q10	2N3819	j-fet
			D1/2/10	1N4148	
			D9	1N5817	

Examples of Component Types

Note variations in shape, size and color of similar component types. Some component leads will need to be reshaped to fit the holes in the PCB.

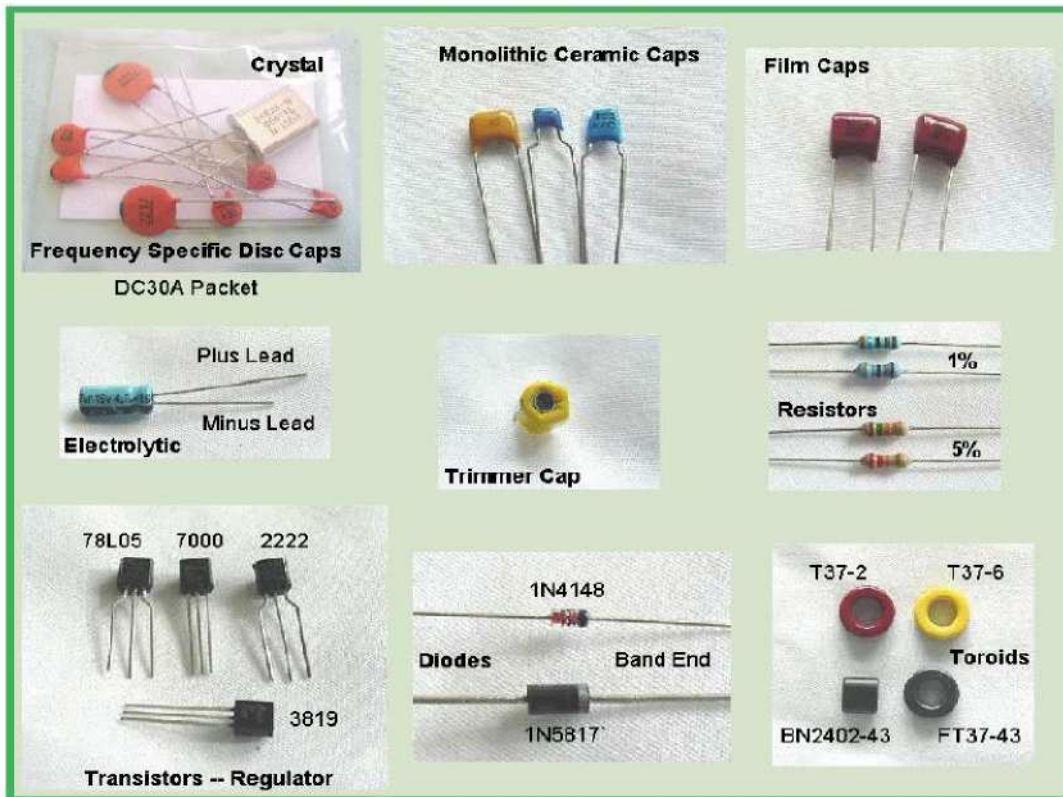

Band specific values

Capacitors	40 meters	30 meters	20 meters	TYPE
C7	47 p	33 p	Not used	C0G or Disk
C31	47 p	47 p	22 p	C0G or Disk
C33	100 p (101)	47 p	22 p	C0G or Disk
C23	68 p	68 p	33 p	C0G
C28	330 p (331)	220 p (221)	150 p (151)	C0G
C29	680 p (681)	560 p (561)	330 p (331)	C0G
C30	330 p (331)	220 p (221)	150 p (151)	C0G

Coil winding data

40 meters	wire	core	turns	Wire length
L1 (Not Used)				
L2	#28 Red	T37-2 (red)	21T	16"
L3	#28 Red	T37-2 (red)	16T	12"
T1	#28 Red/Green	T37-2 (red)	35T sec / 5T link	24" Red, 6" Grn
T2	#28 Red/Green	FT37-43	6T Bifilar	10" Red, 10" Grn
T3	#28 Red/Green	BN2402-43	5T Pri / 1T Sec	5" Red, 2" Grn

30 meters	wire	core	turns	Wire length
L1 (Not Used)				
L2	#28 Red	T37-2 (red)	21T	11"
L3	#28 Red	T37-2 (red)	16T	10"
T1	#28 Red/Green	T37-2 (red)	35T sec / 5T link	24" Red, 6" Grn
T2	#28 Red/Green	FT37-43	6T Bifilar	10" Red, 10" Grn
T3	#28 Red/Green	BN2402-43	5T Pri / 1T Sec	5" Red, 2" Grn

20 meters	wire	core	turns	Wire length
L1 (Not Used)				
L2	#28 Red	T37-6 (yellow)	17T	13"
L3	#28 Red	T37-6 (yellow)	13T	11"
T1	#28 Red/Green	T37-2 (red)	35T sec / 5T link	24" Red, 6" Grn
T2	#28 Red/Green	FT37-43	6T Bifilar	10" Red, 10" Grn
T3	#28 Red/Green	BN2402-43	5T Pri / 1T Sec	5" Red, 2" Grn

Tips and info for first time builders:

Installing parts:

You can insert several parts at a time onto the board. Parts should be pressed flush to the top of the board. The exception is the transistors, which should stand off the board by about 1/8", due to their three legged nature. Once you insert the part, kink one of the leads over slightly to keep it from falling out of the board when you flip the board over to solder.

The .1 uF caps used in the kit have formed leads, so these will not sit quite flush to the board. Several of the DISC caps have lead spacing larger than the pads on the board. These leads you can reform with your pliers so they will sit flush to the board.

Once you solder a part in place, clip the lead nearly flush to the board. Clip at the top of the little fillet of solder which forms around the lead.

Finding the right part.

A picture at the bottom of the parts list on the previous page can be used to help identify some of the parts. The parts not shown should be obvious or deduced by the process of elimination. The numbers identifying the Monolithic caps (mostly yellow in color) can be hard to read. The use of a magnifying glass can help you to see them. In addition to the part value of the capacitor, there are a number of other letters and numbers printed on the part. Simply look for the three number group which matches the value your looking for, 331 for 330 pF, 104 for .1 uF 681 for the 680 pF cap and so on.

IC pin 1.

The outline on the board for the ICs has a "V" notch on one end. This indicates the pin 1 end of the IC. If a socket is used, there is also a notch on one end of the socket. This end goes over the V notch outline on the board. Finally, pin 1 of the IC is marked with a round dimple or dot. This end of the IC will go towards the notch on the socket or "V" on the outline.

Soldering

There are two important things which need to be done to ensure the successful operation of a kit. One is getting the right part into the proper place on the board. The second is good soldering. To insure a good connection, the soldering iron should touch both the component lead and the circuit board pad its to be soldered too. Heat the connection for just a second, then put the solder to the iron/pad/lead junction. Allow just enough solder to flow to fill the hole and wick around the lead. Go easy on the solder, you don't need a whole lot. If you use a thin solder like 0.02" instead of the more common 0.032" type, you have better control of the amount of solder used. For parts which connect to the ground plane, you may have to heat the connection a little longer.

Coils and Transformers

You may find it convenient to wind and prepare all the coils and transformers before you start inserting parts. That way you don't need to stop and possibly loose concentration to wind them for instillation See page 5 for specific band details.

Group 1: Power, Audio and Keyer stages.

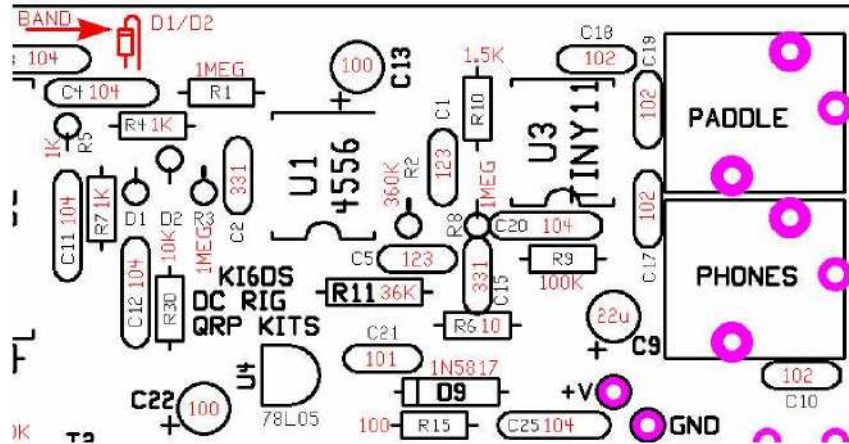

NOTES:

R1 1 and R2 are 1% resistors, so have four color bands for the value, instead of three for the 5% resistors. They also may have a blue body color, instead of tan. C9, C13 The long lead is (+). D1 and D2 are installed "Back to Back", therefore, the black band on the diode (cathode end) should be facing in opposite directions from each other. Do not install the ICs into the sockets until after the initial smoke test.

See next page for required addition of jumper wire on bottom of board

√	Part #	value	markings		√	PART#	VALUE	MARKINGS	TYPE
	R1	1 MEG	BRN/BLK/GRN			C4	.1 uF	104	MONO
	R3	1 MEG	BRN/BLK/GRN			C11	.1 uF	104	MONO
	R4	1 K	BRN/BLK/RED			C12	.1 uF	104	MONO
	R5	1 K	BRN/BLK/RED			C20	.1 uF	104	MONO
	R7	1 K	BRN/BLK/RED			C25	.1 uF	104	MONO
	R10	1.5 K	BRN/GRN/RED						
	R9	100 K	BRN/BLK/YEL			C10	.001 uF	102	DISK
	R6	10 Ohm	BRN/BLK/BLK			C17	.001 uF	102	DISK
	R11	36K, 1%	ORG/BLU/BLK/RED			C18	.001 uF	102	DISK
	R2	360K, 1%	ORG/BLU/BLK/ORG			C19	.001 uF	102	DISK
	R8	1MEG	BRN/BLK/GRN			C1	.012 uF	123	FILM (GREEN)
	R15	100 ohms	BRN/BLK/BRN			C5	.012 uF	123	FILM (GREEN)
	D9	1N5817	Shottky			C2	330 p	331	MONO or DISK
	D1/D2	1N4148	diode			C15	330 p	331	MONO or DISK
	U4	78L05.	+5 regulator			C21	100 p	101	DISK
	U1/3	socket	8 pin			C9	22u/16V	22/16 Alum	RADIAL ALUM ELECTRO
	paddle	jack	stereo			C13	100u/16	100/16 Alum	RADIAL ALUM ELECTRO
	phone	jack	stereo			C22	100 u/16	100/16	RADIAL ALUM ELECTRO

Connection of jumper from U4-3 (output) to U1-3 required for missing 5V buss PCB trace

There was a mistake made when the board was laid out and the connection shown below was missing. The kit builder needs to solder a jumper in place as shown. A solid insulated wire, 26 or 28 ga, should be used for the connection. Solder the jumper in place after U1 and U4 have been soldered.

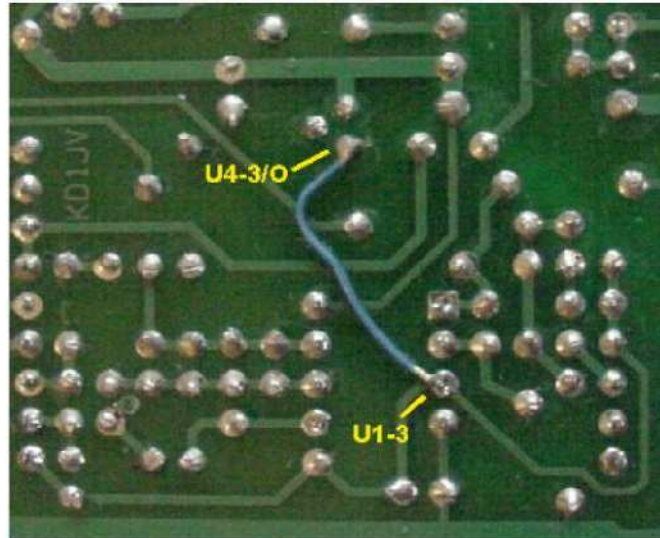

Smoke Test:

Connect the positive lead of a 1 2V power source to the hole marked "+P". Connect the negative lead to the hole marked "G". You can tack these to the bottom of the board, so their easy to remove during further assembly. Apply power to the board. Using a voltmeter, verify there is about 5 volts between pins 4 (ground) and pin 8 (+V) on U3. If this tests good, remove power and insert U3, the ATTINY13 keyer chip (replaces TINY1 1 shown on layout, board and schematic, as the 11 is now obsolete and no longer available) and U1, the 4556 op amp. Insert a pair of headphones into the phones jack, and a paddle or straight key into the paddle jack. Restore power to the board. Using the paddle or straight key, you should hear the side tone in the headphones.

Group 3: Oscillator:

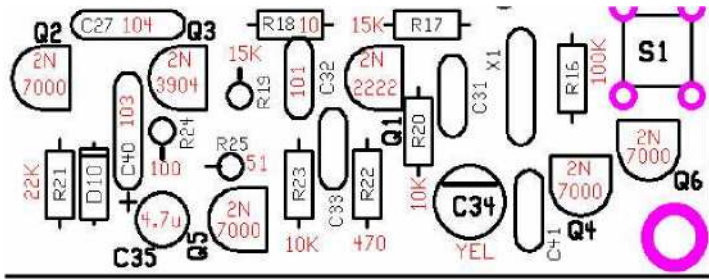

NOTE:

The 2N7000's are mosfets and can be damaged by static. Those who live in dry areas and prone to static problems need to take precautions before handling. This can simply be to touch a large metal object to discharge yourself, before handling the parts.

C34: The flat side of the trimmer goes towards line on layout diagram. C41 not used in 40M version.

S1: You may want to mount the switch on the bottom of the board. If you are going to mount the rig into an Altoids tin, you won't have open the lid to access the switch. If you mount the rig into some other kind of enclosure, mounting the switch on the bottom maybe the only practical way of accessing it.

Smoke Test:

Connect paddle and headphones to board. Connect a test lead antenna to your "big rig" and select the band for which this kit is being built for. Tune the receiver to crystal frequency. Place the test lead antenna near the board. Apply power. Tune the receiver around a little until you hear the boards crystal oscillator. Click and hold closed the switch until you hear the letter "T" in the headphones. The keyer is now in Tune mode. Tapping the DASH paddle will put the rig into transmit mode. It will remain so until you tap the DOT paddle. You can continue to toggle back and forth between transmit and receive using the DOT and DASH paddles. To exit tune mode, click the switch again.

Now you can set the C34 trimmer for the proper T/R oscillator shift. With the board in receive mode, note the frequency of the oscillator. Toggle the board into transmit mode and adjust the C34 trimmer so the oscillator is now 600 Hz higher in frequency than it was when in receive mode. You can also make this adjustment with a frequency counter if you have one. The right hand side of R1 2, located just below U3 is a convent place to connect a counter too.

<i>location</i>	<i>value</i>	<i>markings</i>	√
R18	10 ohms	BRN/BLK/BLK	
R25	51 ohms	GRN/BRN/BLK	
R24	100 ohms	BRN/BLK/BRN	
R22	470 ohms	BRN/VOL/BRN	
R20	10 K	BRN/BLK/ORG	
R23	10 K	BRN/BLK/ORG	
R17	15 K	BRN/GRN/ORG	
R19	15 K	BRN/GRN/ORG	
R21	22 K	RED/RED/ORG	
R16	100 K	BRN/BLK/YEL	
C31 (40M)	47 p	47 DISK	
C33 (40M)	47 p	47 DISK	
C31 (30/2015)	22p	22 DISK	
C33 (30/20/1 5)	22p	22 DISK	
C32	100 p	101 DISK	
C41 (30/20/1 5)	100 p	101 DISK	
C25	.1 uF	104 MONO	
C27	.1 uF	104 MONO	
C40	.01 uF	103 MONO	
C34	40p	Yellow trimmer	
C35	4.7 uF/16V	Alum Electro	
Q1	PN2222A	NPN	
Q3	2N3904	NPN	
Q2	2N7000	mosfet	
Q4	2N7000	Mosfet	
Q5	2N7000	mosfet	
Q6	2N7000	mosfet	
D10	1N4148	diode	
X1		Crystal	
S1	TACT	PB SWITCH	

Group 4: Low pass filter

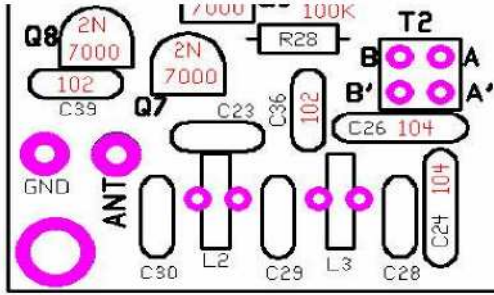

When winding the toroid cores, remember that one pass of wire thru the center of the core is one turn. Also try to keep the wire snug to the outside of the core.

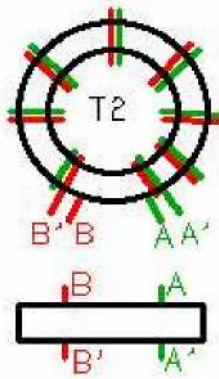

T2 is a bi filler wound transformer. This simply means we wind two wires on the core. Two colors of wire are used to help identify which is which. You can twist the wires together, or simply lay them side by side as you wind the turns. **Wind 6 turns** of the wire pair. (Yes, the diagram shows 8 turns, but only use 6!) When you are done, there will be a red/green pair at the start and finish of the windings. Position the red and green wires on one side of the core so that the ends of the red and green wires are opposite each other on the core, as shown in the diagram above. Now trim back the leads and tin them. Insert the wires into the board, with the red wires in the B holes and the green wires in the A holes, then solder into place.

location	value	markings	✓
C24	.1 uF	104 MONO	
40M:			
C23	68 p	68 DISK	
C30	330 p	331 MONO	
C29	680 p	681 MONO	
C28	330 p	331 MONO	
L2	22 turns	T37-2 (red)	
L3	16 turns	T37-2 (red)	
30M:			
C23	68 p	68 DISK	
C30	220 p	221 MONO	
C29	560 p	561 MONO	
C28	220 p	221 MONO	
L2	14 turns	T37-2 (RED)	
L3	12 turns	T37-2 (RED)	
20M:			
C23	33 p	33 DISK	
C30	150 p	151 MONO	
C29	330 p	331 MONO	
C28	150 p	151 MONO	
L2	17 turns	T37-6 (YEL)	
L3	13 turns	T37-6 (YEL)	

Final Tests.

Your new rig is now just about ready to use. All we need to do now is peak the receiver trimmer and check for transmitter power output.

For peaking the receiver trimmer, on 30 or 40 you can probably just connect an antenna up and peak the trimmer for best band noise or signal if someone is transmitting near the crystal frequency. On 20 and 15, you will probably need to generate a signal using your big rig, transmitting into a dummy load. In this case, you just need to use a piece of wire or clip lead for an antenna on the DC rig and place it near the dummy load. Don't plug in a paddle yet, so you don't accidentally transmit!

For testing the transmitter, you should have a dummy load and watt meter which is reasonably accurate at the 1 watt level. Alternately, you could use a 'Scope if it has enough band width or use a simple diode detector and volt meter.

Connect up an antenna jack if not already done, plug in headphones, paddle and power leads. Turn on power to the rig. Put the keyer into "Tune Mode", using the function switch. This will allow you to toggle the transmitter on and off. Toggle the transmitter on and see if how much power out you get. The amount of power will depend a lot on supply voltage. With 13.8 volts, up to 1 watt and sometimes more is possible. At 12 volts, 700 mW is more likely. Below 12 volts, power output starts to drop quickly. The way the turns are spaced on L2 and L3 can also make a significant difference in the amount of power output, as minor changes in the inductance can affect the matching and power transfer. If your cores are wound with the turns more or less evenly spaced to start with, try moving the turns closer together while watching the power output. Go back and forth between L2 and L3 until you get the most power output you can.

Trouble shooting guide:

The most common reason a kit does not work right is due to soldering issues. Therefore, the first thing to look for if something doesn't work is the solder connections. Look for solder splashes which might be shorting two pads together which shouldn't be connected and for solder which might have stuck just to a lead and didn't flow into the circuit board pad. Connections to the ground plane need extra heat, so look closely to these connections to make sure the solder flowed into the hole. Its also possible to have solder on the circuit board pad, but it didn't flow around the lead.

The second most common error is miss-placed parts. You may have miss read a resistor color code, or put it in the wrong spot. The same goes with capacitors. So, if your soldering looks good, double check the parts placement.

Having an actual bad part is rare. It is possible to damage them though. The 2N7000 can be damaged by static due to improper handling and ICs can be damaged if they are installed backwards.

Some DC voltage levels are shown on the schematic, along with some wave forms. Note that the DC voltage across R22, the crystal oscillator emitter resistor measures a lot higher than the base voltage, because of the way the DVM responds to the superimposed AC RF voltage.

Low Audio

The Dcxx audio output is adequate for most headphones, especially the higher impedance types. If you are experiencing low audio, try a different headset. Those with the highest sensitivity ratings are best. If you still find the volume too low, you can add a simple audio amplifier. Circuits and kits using the popular LM386 can be found on the internet. A mini audio amp, 2 cm x 2 cm x 10 mm, assembled and tested with 2.5" attached leads is available from W5USJ. This amp can be attached in place of R5, or in series with the headphone jack, using suitable connectors. For more details, visit <http://w5usj.com/miniaudioamp.html> or email w5usj@qrparci.net

Making contacts with a fixed frequency, Direct Conversion rig.

Making contacts with this type of rig can be a challenge, but its not impossible. In fact, it can be a lot of fun and satisfying. Just remember, its easier to have stations come to you. The reason for this is because the receiver will hear stations on both sidebands, you don't know which side band your hearing them on. They could be on your transmit frequency of 7.040000 or down at 7.038800. Also, although the audio band pass filter adds some selectivity, its hard to tell how close to your operating frequency they really are, especially if the station is pretty strong. You could be hearing them well, but your transmitting too far from their operating frequency for them to hear you. That being said, it can pay to try and answer a CQ you hear anyway, especially if they are signing QRP or QRPp. Then you pretty much know they are on 7.040 and some operators actually use RIT to tune around a little for answering stations. Or they could be using one of these rigs or a Rock Mite.

It also helps to carefully pick the time of day and day of the week to operate this rig. You want to pick a time of day and day of the week when the band isn't overly active. Contest weekends and early evening prime time are out. Good times are Sunday afternoon or evening, mornings, afternoons and late evenings during the week.

Keyer operation:

The momentary switch is used to access the keyer functions. Clicking and holding closed the switch for various lengths of time access these functions. There are five possible functions which are selected using the "Function" Switch. These are:

1. Send message
2. Set code speed
3. Enter and exit Tune Mode
4. Enter store message mode
5. Change from Iambic B to A mode.

NOTE: Earlier kits using the ATTINY1 1 keyer chip do not support keyer memory, so functions 1 and 4 are not applicable.

Sending messages: (A message must be stored before this function will work)

After a short, quick click of the function switch, tap the Dot paddle to send message 1 or tap the Dash paddle to send message 2. Once a message has started to be sent, it can be paused, stopped or set to beacon mode. Note: only message 1 can be used for beacons.

Pause: Close and hold the Dash paddle.

Stop: Close and hold the Dot paddle.

NOTE: these actions will occur after a character currently being sent has finished sending.

Beacon mode:

Click and hold the function button as Message 1 is being sent. The letter "B" will sound from the side tone when the mode is activated. There is a fixed 3 second pause between repeating the message. Closing either paddle during the pause will terminate beacon mode. In addition, message Pause and Stop may be used during the sending of the message.

Change code speed:

A short, quick click of the switch enters change code speed mode. There is a short pause to see if you want to send a message, then letter "S" will be sounded by the side tone.

- Closing the Dash paddle will increase the code speed, a dot will sound each time the speed is incremented by 1 wpm.

- Closing the Dot paddle will decrease the code speed. Again, a dot will sound each time the speed is decremented by 1 wpm.
- At the upper and lower speed limits, a double dot (I) will sound.
- The change code speed mode will automatically exit after the paddles have been released for about 1 second.

Tune mode:

Tune mode is used when you want to key the transmitter continuously to say adjust an antenna tuner or make a power output measurement. To enter Tune mode:

- Click and hold closed the function switch until the letter "T" is sounded by the side tone (about 1 second)
- To key the transmitter on, tap the Dash paddle closed.
- To turn the transmitter off, tap the Dot paddle closed.
- Repeat as needed.
- To exit Tune mode and return to normal operation, click the Function switch.

Entering Messages:

- Click and hold the function switch closed until the letter "M" is sounded by the side tone, about 1 second after the tune mode annunciation of "T".
- A message of up to 29 characters (including word spaces) may now be entered via the paddle. If you exceed the maximum character limit, "EM" will sound and you will have to start again, making the message shorter. If you have a 2X3 call, you won't be able to quite fit a 3x3 CQ into the memory.
- "Ideal" timing of 7 dot times for character space and 21 dot times for word spacing is used to determine the completion of a character or word space. To insure a word space is inserted, it is best to pause slightly longer than you would otherwise between words.
- Click the Function switch when you are finished entering the message. The message will repeat so you can check for timing errors. If you need to re-enter the message, click the Function button and "EM" will sound.
- If the message was entered correctly, tap the Dot paddle to store the message in location 1 or the Dash paddle to store in location 2. "MS" (message stored) will sound and normal operation will resume.

Selecting Iambic A/B mode:

Click and hold closed the Function switch until the letter "A" or "B" is sent by the side tone. If the keyer was in "A" mode, "B" will sound, indicating it has switched to B mode. The mode selection is stored in EEPROM memory and the selected mode used on power up. ATTINY 11 keyer chip does not remember mode selection and must be reset on power up.

The difference between A mode and B mode:

Iambic keying is when you close both paddles and get alternating dot and dashes as long as the paddles are closed. The difference between A and B modes is what happens when the paddles are released. In A mode, when you release the paddles, the dot or dash currently being set will end the string. In B mode, an extra dot or dash will be inserted at the end of the string, depending on which element was being sent when the paddles were released. B mode takes some getting used to, but it reduces the number of paddle closures needed to generate some letters.

B mode is a little tricky to implement in software. The main question is when does it decide that both paddles are closed? Dot and Dash memory is implemented so that you can "key ahead" of the sending of code elements. Without this, it is easy to drop dots or dashes. This test is done while a code element is being sent, but this is not a good time to test for both paddles closed, as you might not have quite released the other paddle yet or there could be switch bounce. Therefore, the both paddles closed test is done at the start of the inter-code element space. Because of this, both paddles have to be held closed into the space in order to get the extra element inserted. This is not a problem at higher code speeds, but might be a slow speeds.

Straight key mode:

If a mono plug is in the paddle jack at power up, the keyer will go into straight key mode. In this mode, there is no need for the function switch, so it is disabled. This function allows using an external contest keyer if desired.

How it works:

Receiver:

Signals from the antenna first travel through the transmitters low pass filter. It then passes through a T/R QSK switch comprised of two, 2N7000 mosfets. During receive, Q9 is turned on and Q8 is turned off. This allows the signal to pass into the link coupling into the front end tuned circuit. During transmit, Q9 is turned off and Q8 is turned on, isolating the transmit signal from the receiver. Q7 is used as an inverter, as Q9 and Q* need complementary logic signals.

The tuned input circuit is connected to a j-fet amplifier to isolate the mixer from the antenna and to provide some gain. The 10 ohm resistor in the Source lead prevents VHF oscillations. The output of the amplifier is then coupled into the mixer using a transformer wound on a small balun core. The mixer is an analog multiplexer. The analog switches in the multiplexer connect the output load resistor across the secondary of the input tuned circuit at the LO frequency rate. On each half cycle, the phase of the input signal across the load resistor is switched. This produces the mixing of the LO signal and input signal, producing an audio beat note at the load resistor. Note that there is no bias voltage on the analog switches. Biasing the switches to 1/2 the supply voltage would improve the mixers' dynamic range, but was found not to be necessary. Any signal strong enough to overload the mixer with out bias, would "blow your ears off".

A high gain, differential input audio amplifier is connected to the mixers' load resistor. This stage provides most of the gain for the receiver. A pair of back to back diodes across the amplifiers feedback resistor limits the peak to peak output of the amplifier, to offer some hearing protection from strong signals. These diodes also reduce clicks created by switching transits when switching from receive to transmit and back again.

The output of the first high gain audio stage is then routed though another analog switch, again without bias, for audio muting during transmit. The signal then goes into an audio band pass filter stage. This filter has a Q of 8. However, since only a single stage of filtering is provided, the filter isn't as narrow as a Q of 8 would imply when strong signals are present. The output of this filter drives the headphones. A 10 ohm resistor helps keeping the amplifier stable when driving the relatively low impedance of headphones and the .001 cap across the output helps keep RF, which might be picked up by the headphone leads, out of the amplifier. The NJM4456 op amp used has a high current output, so has no trouble driving headphones.

Oscillator and transmitter.

A classic Colpits crystal oscillator provides the Local Oscillator. During receive, Q4 is turned on, which disables any effect C34 has on the oscillator frequency. During transmit, Q4 is turned off, allowing C34 to increase the oscillator frequency. C34 is used to set the transmit frequency about 600 Hz higher than the receive frequency, providing proper T/R offset. When going from receive to transmit, the keyer chip will first mute the receiver and shift the oscillator frequency before enabling the transmitter output. When going from transmit to receive, the transmitter is first turned off, then after a delay of about 5 ms, the receiver is un-muted and the oscillator frequency shifted.

Q3 buffers the LO output signal in order to drive the PA. This stage is turned on an off by the keyer chip, with the help of Q5. R23 and R25, in combination with C35 form an R/C time constant which causes the output of Q3 to ramp on and off in about 5 ms. This provides wave shaping to the output signal, as to eliminate key clicks.

The output of Q3 in turn drives the PA stage, a 2N7000 MOSFET. Diode D10 across the gate acts to double the drive voltage by charging the coupling cap, C27 on negative cycles. This ensures there is enough drive voltage to turn Q2 reasonably well on. The output of the PA, Q2 is coupled to the low pass filter through a bi filler wound transformer. This provides some impedance matching and increase power output and efficiency. Capacitor C23 tunes the L3 coil to the second harmonic, which forms a trap. This ensures the spurious output of the transmitter is well below required FCC limits. It also improves PA efficiency and power output.

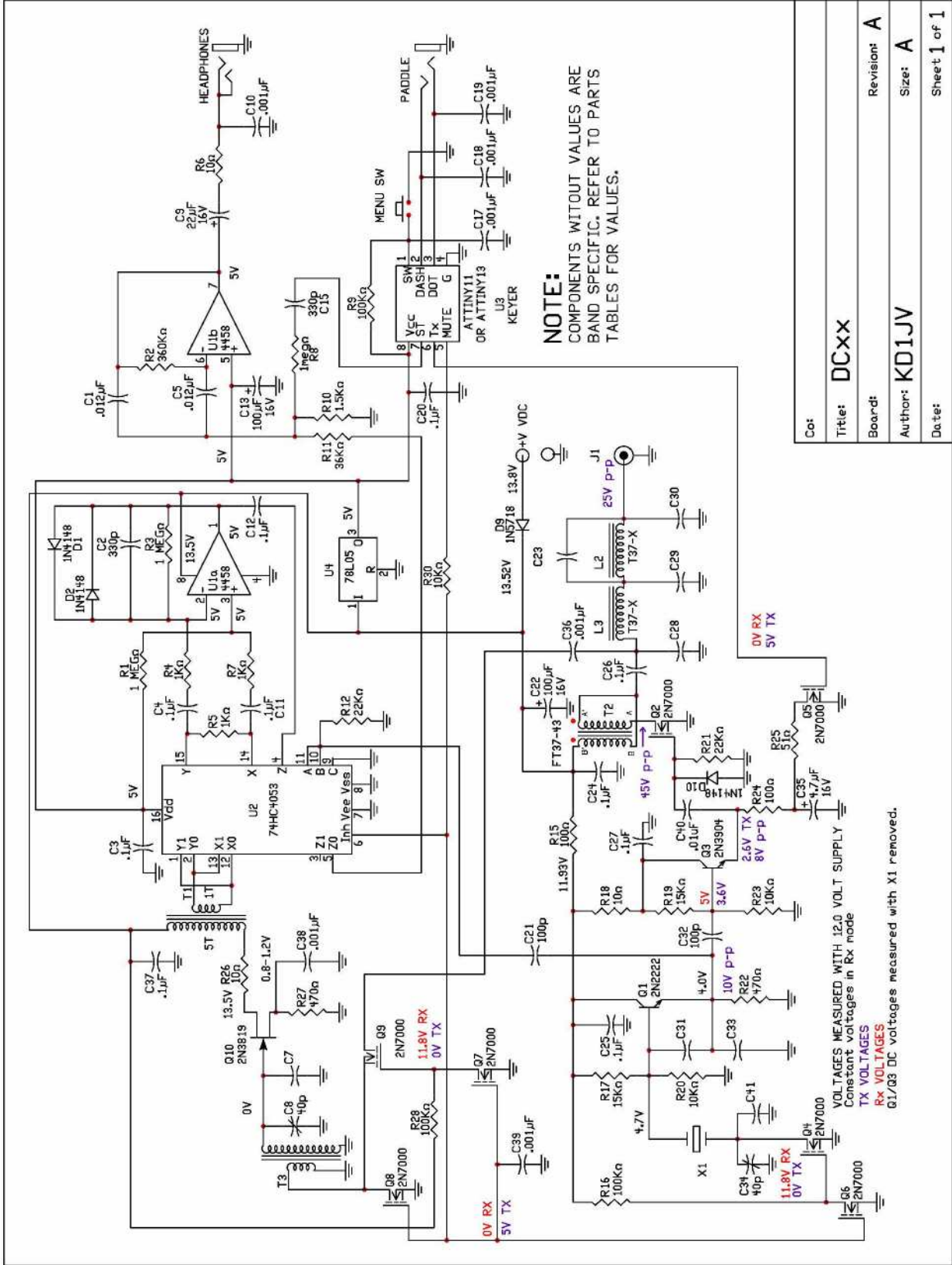

NOTE:
COMPONENTS WITHOUT VALUES ARE
BAND SPECIFIC. REFER TO PARTS
TABLES FOR VALUES.

Co:	
Title:	DCXX
Board:	
Author:	KD1JV
Date:	
Revision:	A
Size:	A
Sheet	1 of 1

VOLTAGES MEASURED WITH 12.0 VOLT SUPPLY
Constant voltages in Rx mode
Rx VOLTAGES
Tx VOLTAGES
Q1/Q3 DC voltages measured with X1 removed.